

e-ISSN:2582-7219



INTERNATIONAL JOURNAL OF MULTIDISCIPLINARY RESEARCH IN SCIENCE, ENGINEERING AND TECHNOLOGY

Volume 5, Issue 10, October 2022



INTERNATIONAL
STANDARD
SERIAL
NUMBER
INDIA

Impact Factor: 7.54



6381 907 438



6381 907 438



ijmrset@gmail.com



www.ijmrset.com



Single Stage Advanced High Power Factor Correction Converter for Charging Applications

Aneesh S, SarunKumar KP, Anitha Mathew, Negma Iqbal, Aswathy Vidyagar

Assistant Professor's, Department of Electrical and Electronics Engineering, IES College of Engineering, Kerala, India

ABSTRACT: The proposed PFC converter features sinusoidal input current, three level output characteristic, and a wide range of output dc voltages, and it will be very suitable for high-power applications where the output voltage can be either lower or higher than the peak ac input voltage, e.g., plug-in hybrid electric vehicle charging systems. Moreover, the involved dc/dc buck conversion stage may only need to process partial input power rather than full scale of the input power, and therefore the system overall efficiency can be much improved. Through proper control of the buck converter, it is also possible to mitigate the double-line frequency ripple power that is inherent in a single-phase ac/dc system, and the resulting load end voltage will be fairly constant. The dynamic response of this regulation loop is also very fast and the system is therefore insensitive to external disturbances. The simulation results are presented to show the effectiveness of this converter as well as its efficiency improvement against a conventional two-stage solution.

KEYWORDS: Battery, Power factor correction (PFC), dc-dc converter, Pulse Width Modulation (PWM)

I. INTRODUCTION

An AC/DC converter is one of the most effective power electronics devices found in many consumer electronic devices like in television sets, personal computers, battery chargers. They find use in industries dealing with mainly variable speed drive and electric vehicle chargers. Single-phase power factor correction (PFC) converters are known for being simple, cost effective, and also because they provide efficient current shaping. Almost all the single-phase PFC converters which are in use today are of boost type, which implies that they provide an output voltage that is higher than the peak voltage of the ac input. In plug-in hybrid electric vehicle (PHEV) charging systems the terminal voltage of battery may lie between 100 V and 600 V. This means that a wide range of output voltage is indeed desired in such applications. In the existing systems, a second stage dc/dc buck converter has to be implemented to step down the PFC output voltage, which, however, reduces the system overall efficiency. To add to this, the systems are sensitive to external disturbances.

The simulation results are presented to show the effectiveness of the proposed converter showing the power factor improvement and improved output voltage.

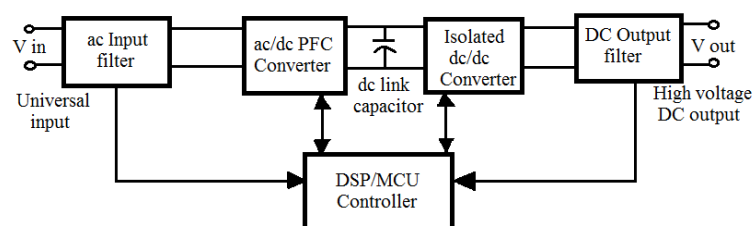

Fig. 1. Simplified system block diagram of a Universal battery charger.



The most common charger power architecture includes an ac–dc converter with power factor correction (PFC) followed by an isolated dc-dc converter with input and output EMI filters, as shown in Fig. 1. Selecting the optimal topology and evaluating power loss in the power semiconductors are important steps in the design and development of PHEV battery chargers. The front-end ac–dc converter is a key component of the charger system. Proper selection of this topology is essential to meet the regulatory requirements for input current harmonics, output voltage regulation and implementation of power factor correction.

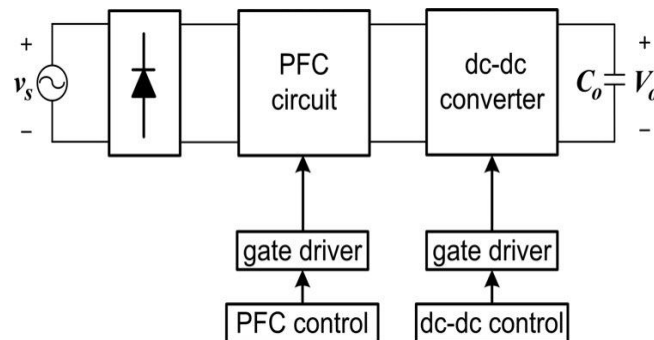

Fig.2.Two-Stage Single-Phase PFC Converter

A typical Two-Stage Single-Phase Power factor correction Converter as shown in Fig.2 comprises of separate control and driver circuits for the DC-DC Converter and the Power factor Correction circuit, thus forming a two stage process for power factor correction. This not only increases the manufacturing cost, but is also accompanied by Power losses. There is a need to use PWM pulses in each block as Power factor correction (PFC) and dc to dc conversion is done separately. A highly distorted input current is associated with these existing systems. Due to the above reasons the previously existing systems are complex in nature.

For single-phase ac/dc rectifiers, literature studies were being carried out. The performance of a buck-topology-based PFC converter, which can produce a lower output dc voltage but provide high efficiency under universal line voltage were discussed in detail. A new interleaved boost PFC converter which provides soft switching for the power MOSFETs, through an auxiliary circuit which gives reactive current during the transition times of the MOSFETs to charge and discharge the output capacitors of the MOSFETs was proposed [2]. A new front end ac–dc bridgeless interleaved power factor correction mechanism for plug-in hybrid electric vehicle (PHEV) battery chargers [3] can have high efficiency, that is helpful to reduce the size of the charger, PHEV charging time and cost of electricity used from the utility. Since the proposed topology shows high input power factor, high efficiency over the entire load range, and low input current harmonics, it is a potential option for single phase PFC in high power level II battery charging applications.

The survey in [4] studies several boost power factor corrected converters, which offers different levels of efficiency, power factor, density, and cost. The results demonstrate that the phase shifted semi-bridgeless PFC boost converter is ideally suited for automotive level I residential charging applications, where the typical supply is limited to 120 V and 1.44kVA or 1.92 kVA. For automotive level II residential charging applications in North America and Europe the bridgeless interleaved PFC boost converter is an ideal topology candidate for typical supplies of 240 V, with power levels of 3.3 kW, 5 kW, and 6.6 kW. Analysis and design of a low-stress buck-boost converter in [7] deals with analysis of the converter operation and component stresses, as well as design guidelines.

A buck PFC converter with power decoupling capability has been proposed in the past, and it features high-quality input current as well as ripple free output voltage. However, the limitation of this topology is that, its output voltage must be lower than half of the peak ac input voltage, and this reduces the output voltage range during low-line operation. Thus after analyzing all the past works, it can be said that out of the many integrated bidirectional ac/dc and dc/dc converter topologies proposed earlier, which combines all necessary operation modes that are required for the power converter of PHEVs, namely plug-in charging from power grid, vehicle-to-grid discharge, pumping power to drive electric motor, and regenerative braking, despite its powerful functionalities, involves a number of semiconductor devices, and thus, may not be ideal for an optimized efficiency and cost-effective solution.



II. SINGLE STAGE HIGH POWER FACTOR CONVERTER

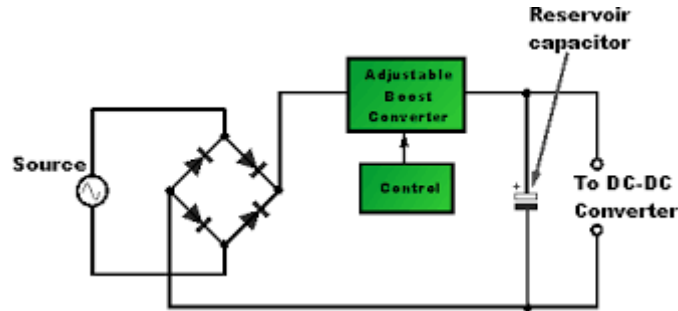

Fig. 3.A Typical PFC Circuit

A single-phase power factor correction (PFC) converter that has flexible output voltage and improved conversion efficiency is proposed. The PFC converter features sinusoidal input current, three level output characteristic, and a wide range of output dc voltages, and it will be very suitable for high-power applications where the output voltage can be either lower or higher than the peak ac input voltage, e.g., plug-in hybrid electric vehicle charging systems. Through proper control of the boost converter, it is also possible to mitigate the double line frequency ripple power that is inherent in a single-phase ac to dc system, and the resulting load end voltage will be fairly constant. The dynamic response of this regulation loop is also very fast and the system is therefore insensitive to external disturbances. The power factor and dc to dc operation done in single stage only, the system overall efficiency will be increased and the power losses going to reduced in this single stage operation.

A. Operating principle and System Description

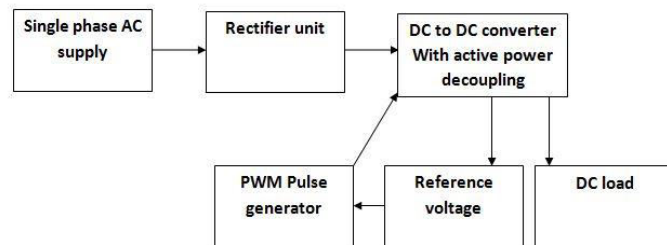

Fig.4.Single stage high Power factor Converter

In the proposed topology PF corrected circuit and dc to dc conversion circuit combined in single stage (single circuit) as shown in Fig. 4. In existed systems, the DC to DC converter circuit and PFC circuit has worked separately, so they create power losses and they required two different control parts. But in the proposed system, the one circuit will act as a DC to DC circuit and the same circuit automatically corrects the Power factor.

There is a single circuit for PF corrected circuit and dc to dc conversion. Sinusoidal input current, and a wide range of output dc voltages is obtained in this system. The output voltage can be either lower or higher than the peak ac input voltage. Also, Dc to dc boost conversion stage may only need to process partial input power rather than full scale of the input power.

The proposed PFC has a wide range of output voltages and it can function as either a buck or a boost converter. The circuit in Fig. 5 will act as a DC to DC conversion circuit and the same circuit automatically correct the Power factor. With reference voltage, the PWM pulse is generated.

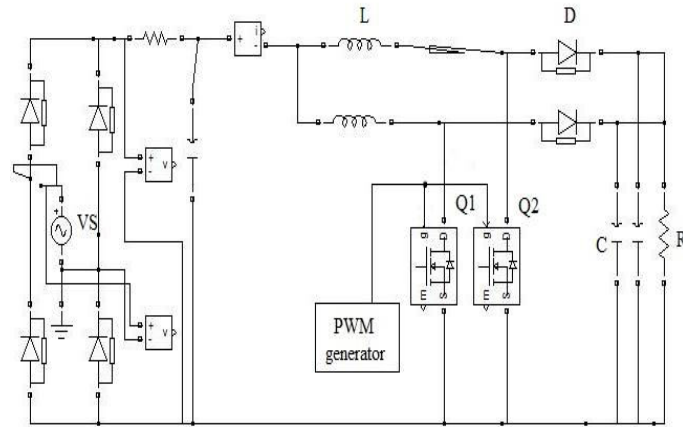

Fig. 5. Circuit diagram for the proposed system

During the buck operation, there are two operation modes for Q1 and Q2. When the load voltage V_L is higher than the instantaneous input voltage $V_{in} |\sin\omega t|$, where V_{in} is the peak value of input voltage and ω is the fundamental angular frequency, Q2 will be always on. Q1 and D1 then form up a standard boost PFC that directly converts input power for dc load consumption, and the converter pole voltage V_{AB} will be changed between 0 and V_L . In order to realize the PFC function, the duty cycle of Q1 should comply with

$$d_2 = 1 - \frac{V_{in} |\sin\omega t|}{V_L} \quad (1)$$

which is the basic equation for a boost PFC. In this operation period, Q3 and Q4 of the buck converter theoretically do not need to switch because all input power can be directly supplied into the load through D1 and Q2. However, in order to obtain a smooth output voltage, Q3 and Q4 still need to work and provide ripple power compensation during this operation period.

In the second operation interval when V_L is less than $V_{in} |\sin\omega t|$, Q1 remains OFF. Q2 and D2 will act as boost PFC. In this case, the converter pole voltage V_{AB} is changing between V_L and the high DC bus voltage V_H . Again, to have a sinusoidal input current and unity power factor, the duty cycle of Q2 must comply with

$$d_2 = 1 - \frac{V_{in} |\sin\omega t| - V_L}{V_H - V_L} \quad (2)$$

Also, the dc/dc converter may only process partial input power. This is because when D2 is conducting, excessive input power passes into the dc-link capacitor CH and the high bus voltage will be subsequently stepped down by the bidirectional dc/dc converter to cater for load consumption. This is the root cause for higher conversion efficiency in the proposed topology.

B. Pulse-Width Modulation (PWM)

In general for a PWM techniques two signals are needed namely the reference signal and the carrier signal. The reference signal is going to modify, whereas carrier is taken as a triangular wave here. Some of the different modified reference signals are Sinusoidal Pulse width modulation, Trapezoidal PWM, Stair case PWM, Stepped PWM. With the help of a reference voltage PWM pulse is generated. These PWM pulses are given as gate pulses for the converter. The pulse-width modulation (PWM) generator produces the pulses and activates the MOSFETs alternatively as in the circuit in Fig.5 and Fig.6. Here, the triggering to both the MOSFET is fed by a single PWM pulse generator as shown in the circuit.



C. Applications and system efficiency

Some of the Applications of the proposed Converter circuit are E-cars charging applications and Laptop adopters. The main features include reduced power losses, maintenance of power factor, maintenance of load life time and efficiency. It is also expected that the output harmonics and load running noises are less. The inherent fluctuating power issue in single-phase systems can be resolved and the load voltage will be fairly constant and insensitive to load changes and external disturbances. The single stage high power factor converter has flexible output voltage and improved conversion efficiency. Moreover the involved dc to dc boost conversion stage may only need to process partial input power rather than full scale of the input power, and therefore the system overall efficiency can be much improved. Through proper control of the boost converter, it is also possible to mitigate the double line frequency ripple power that is inherent in a single-phase ac to dc system

III. SIMULATION RESULTS

Simulation study was carried out in MATLAB/Simulink environment with Power factor and Output voltage as the parameters. The single PWM generator gives the pulses to the two MOSFETS alternatively and this makes room for Power factor correction. The power factor correction is done as a whole through the MOSFET and filter.

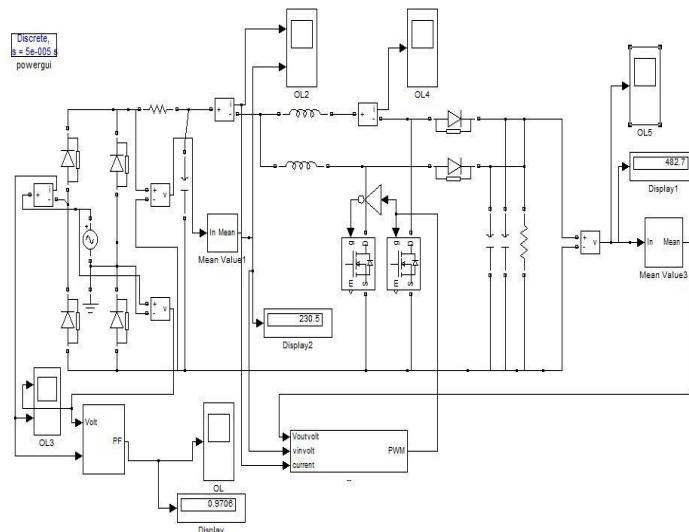

Fig. 6. Single stage high Power Factor Converter- Matlab circuit diagram.

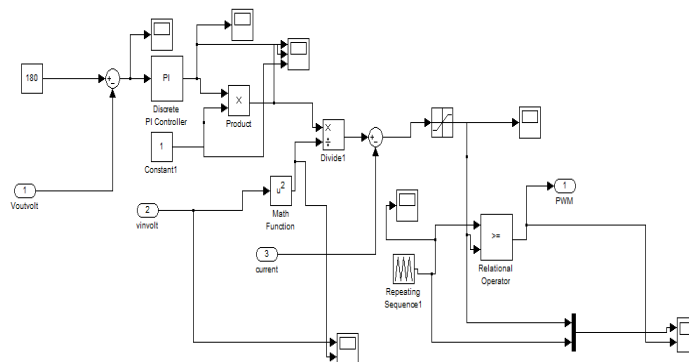

Fig.7. PWM Controller

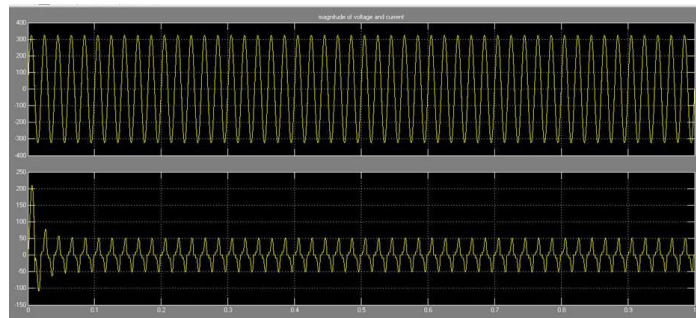

Fig. 8. Input Voltage and Current Waveforms

The simulation results show that there has been an increase in the voltage level in the output end which is almost double the input voltage. The same has been depicted in Fig. 8 and in Fig. 9. The Power factor in the input line is found to be 0.97 with the above mentioned method as shown in Fig. 10.

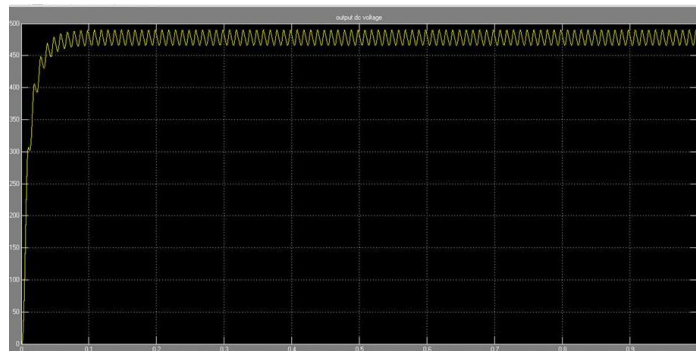

Fig. 9. Output DC voltage



Fig. 10. Power factor

It should be noted that the power losses in the gatedrivers were not included in the efficiency measurement. Since the required gate charge is low and the adopted switching frequency is also relatively slow, these power losses are insignificant to the system overall efficiency.

IV. EXPERIMENTAL SETUP

A prototype circuit was built in the laboratory for experimental validation of the proposed PFC converter and the circuit parameters are basically the same as those used in simulation, despite some very slight differences due to the tolerance of passive components.



V. CONCLUSION

It can be concluded that proposed PFC converter features sinusoidal input current, three level output characteristic, and a wide range of output dc voltages, and it will be very suitable for high-power applications where the output voltage can be either lower or higher than the peak ac input voltage, the plug in hybrid electric vehicle charging systems. The single stage high power factor converter has flexible output voltage and improved conversion efficiency. Moreover the involved dc to dc boost conversion stage may only need to process partial input power rather than full scale of the input power, and therefore the system overall efficiency can be much improved. Through proper control of the boost converter, it is also possible to mitigate the double line frequency ripple power that is inherent in a single-phase ac to dc system, and the resulting load end voltage will be fairly constant. The dynamic response of this regulation loop is also very fast and the system is therefore insensitive to external disturbances. The power factor and dc to dc operation done in single stage only, the system overall efficiency will be increased and the power losses going to reduced in this single stage operation.

REFERENCES

- [1] Yi Tang, Dexuan Zhu, Chi Jin, Peng Wang and Frede Blaabjerg, "A Three-Level Quasi-Two-Stage Single-Phase PFC Converter with Flexible Output Voltage and Improved Conversion Efficiency," *IEEE transactions on power Electronics*, vol. 30, no.2, pp 717-726, February 2015.
- [2] L. Huber, Y. Jang, and M. M. Jovanovic, "Performance evaluation of bridgeless PFC boost rectifiers," *IEEE Trans. Power Electron.*, vol. 23, no. 3, pp. 1381–1390, May 2008.
- [3] F. Musavi, W. Eberle, and W. G. Dunford, "A high-performance single phase bridgeless interleaved PFC converter for plug-in hybrid electric vehicle battery chargers," *IEEE Trans. Ind. Appl.*, vol. 47, no. 4, pp. 1833–1843, Jul./Aug. 2011.
- [4] F. Musavi, M. Edington, W. Eberle, and W. G. Dunford, "Evaluation and efficiency comparison of front end AC–DC plug-in hybrid charger topologies," *IEEE Trans. Smart Grid*, vol. 3, no. 1, pp. 413–421, Mar. 2012.
- [5] M. Pahlevaninezhad, P. Das, J. Drobnik, P. K. Jain, and A. Bakhshai, "AZVS interleaved boost AC/DC converter used in plug-in electric vehicles," *IEEE Trans. Power Electron.*, vol. 27, no. 8, pp. 3513–3529, Aug. 2012.
- [6] C. Marxgut, F. Krismer, D. Bortis, and J. W. Kolar, "Ultraflat interleaved triangular current mode (TCM) single-phase PFC rectifier," *IEEE Trans. Power Electron.*, vol. 29, no. 2, pp. 873–882, Feb. 2014.
- [7] *Electromagnetic Compatibility (EMC)—Part3: Limits—Section 2: Limits for Harmonic Current Emissions (Equipment Input Current <math>< 16 A Per Phase)</math>*, IEC Standard 61000-3-2, 1998.
- [8] Y. J. Lee, A. Khaligh, and A. Emadi, "Advanced integrated bidirectional AC/DC and DC/DC converter for plug-in hybrid electric vehicles," *IEEE Trans. Veh. Technol.*, vol. 58, no. 8, pp. 3970–3980, Oct. 2009.
- [9] O. Onar, J. Kobayashi, and A. Khaligh, "A bidirectional high-power quality grid interface with a novel bidirectional non-inverted buck-boost converter for PHEVs," *IEEE Trans. Veh. Technol.*, vol. 61, no. 5, pp. 2018–2032, Jun. 2012.
- [10] D. M. Van De Sype, K. De Gussemé, A. P. M. Van den Bossche, and J. A. Melkebeek, "Duty-ratio feedforward for digitally controlled boost PFC converters," *IEEE Trans. Ind. Electron.*, vol. 52, no. 1, pp. 108–115, Feb. 2005.
- [11] R. Martinez and P. N. Enjeti, "A high performance single phase AC to DC rectifier with input power factor correction," *IEEE Trans. Power Electron.*, vol. 11, no. 2, pp. 311–317, Mar. 1996
- [12] U. Moriconi, "A bridgeless PFC configuration based on L4981 PFC controller," Application Note AN 1606, STMicroelectronics, 1/18–18/18 Nov. 2002.
- [18] A. F. Souza and I. Barbi, "High power factor rectifier with reduced conduction and commutation losses," in *Proc. Int. Telecommunication Energy Conf.*, Jun. 1999, pp. 8.1.1–8.1.5.
- [19] X. Xie, C. Zhao, L. Zheng, and S. Liu, "An improved buck PFC converter with high power factor," *IEEE Trans. Power Electron.*, vol. 28, no. 5, pp. 2277–2284, Feb. 2013.
- [20] Y. Ohnuma and J. Itoh, "A novel single-phase buck PFC AC–DC converter with power decoupling capability using an active buffer," *IEEE Trans. Ind. Appl.*, to be published.



INNO SPACE
SJIF Scientific Journal Impact Factor
Impact Factor
7.54

ISSN

INTERNATIONAL
STANDARD
SERIAL
NUMBER
INDIA



INTERNATIONAL JOURNAL OF MULTIDISCIPLINARY RESEARCH IN SCIENCE, ENGINEERING AND TECHNOLOGY

| Mobile No: +91-6381907438 | Whatsapp: +91-6381907438 | ijmrset@gmail.com |

www.ijmrset.com