



INTERNATIONAL JOURNAL OF MULTIDISCIPLINARY RESEARCH IN SCIENCE, ENGINEERING AND TECHNOLOGY

Volume 5, Issue 6, June 2022



INTERNATIONAL
STANDARD
SERIAL
NUMBER
INDIA

Impact Factor: 7.54



9710 583 466



9710 583 466



ijmrset@gmail.com



www.ijmrset.com



Arduino Based Child Rescue System from Borewells

A.NAVEEN KUMAR V.PRABAGARAN, R. MOTHU

Assistant Professor, Department of Electronics and Communication Engineering, Mahendra Engineering College,
Tamilnadu, India

Department of Electronics and Communication Engineering, Mahendra Engineering College, Tamilnadu, India

Department of Electronics and Communication Engineering, Mahendra Engineering College, Tamilnadu, India

ABSTRACT: For previous few years, there have been various accidents of young people falling into an deserted bore-well which is left uncovered and get trapped. Abandoned bore wells looks to be dying pits for children. These bore-wells in flip have started out to take many harmless lives. In such instances ordinary operations of toddler rescue from bore-wells is very intricate procedure with massive machines and massive man power. The purpose of this paper is to rescue youth falling in to bore-wells, this implies a new sketch which has a sensor stored at pinnacle of bore-well gap which helps to feel the baby if he falls inside. If the device senses the baby the computerized horizontal closure stored at round 10ft depth closes and prevents the adolescents from falling beneath, it has the facility to reveal the trapped child, and supply a aiding platform to raise up the baby pushed by way of motors. The motor positioned at the pinnacle turns a equipment mechanism which, in turn, pushes three blocks organized at a hundred and twenty ranges from every different in the direction of the facet of the bore well. The entire gadget is firmly to the bore-well wall. The 2nd motor positioned below the plate turns the backside shaft via 360 degrees, thereby assisting to detect the hole thru which the lifting rod passes.

KEYWORDS: Child safety, Internet Of Things, IR Sensor, Wireless Network.

I.INTRODUCTION

Recently, many accident reviews of teenagers (and even adults) falling in open bore-wells have regarded in the print and the digital media. Very few of the victims have been saved in such accidents. In some of these instances the useless physique of the difficulty should no longer be gathered easily. Even if rescued late, most victims have been reportedly injured. To overcome such issues of these rescue operations, we have an choice (feasible) proposal. We are creating a robot computer that can take out the trapped physique in systematic way. It will additionally function quite a number life-saving operations for the victims such as oxygen supply. A video digicam to look at the authentic state of affairs carefully and non-stop interplay with the sufferer should additionally be attached. It will be a mild weight computing device that will go down into the bore properly pipe and keep the trapped physique systematically.

This laptop meeting will be supported with the aid of a cable wire and this will be managed and supported by way of a equipment assembly. In this choice scenario, there will be no requirement of digging any total parallel to the bore-well. The remotely managed robotic will go down the bore properly and function the action. A lot of different hassles will additionally be prevented through this choice technique. The rescue of these trapped teenagers in an uncovered bore-well is now not solely challenging however additionally risky. A small extend in the rescue can misplaced the baby his or her life. To raise the baby out the slender confines of the bore wells is additionally no longer very easy. The baby who has suffered the trauma of the fall and is restricted to a small region where, with a passage of time the furnish of oxygen is additionally reduces. Robot for bore nicely rescue affords a answer to these sorts of situations. It is fast, within your means and safe.



II.LITERATURE REVIEW

Bharathi.Bet.al[1] depicts the plan of a robot for saving the kid from bore well. This robot is fit for moving underneath the drag well, as per the human comment by Pc, it will pick and spot dependent on the arm structures. It is worked through Pc with the assistance of remote zigbee innovation and remote camera which is used for video surveillance. The main drawback is that the arm structure can't give adequate security to the child while lifting.

Manish Raj et.al[2] depicts as the dimension of the drag well is slender for any grown-up in difficult and bright goes dim inside it, the rescuing task in that circumstance is very difficult. The automated framework which will join an outfit to the child utilizing inflated arms for rescuing the child. The video chatting method is also available for speaking with the child. The robotic arm is like clipper, so that the lifting mechanism is very difficult

Giridharan.Met.al[3] described about designing a robot consists of three engines to save a child on the drag well. The primary engine is used for movement which is up and down by using screw bar. Second engine is utilized for grabbing reason with the surface of lead screw arrangement. Another engine is used to rescue the child through rack and pinion arrangement. Based on the location of the child, the whole arrangement can be pivoted. Then the child is lifted from the bore well.

Arthika.Set.al[4] described about the mechanism of safeguarding child from the bore well. The temperature sensor is used to detect the temperature and similarly gas sensor is used to detect the gas spillage in the specific region. ARM compression and expansion method is used for roper up and down movement. The robotic arm is using relay operation for picking and placing the child. This method provides safeguarding activities in less time. The major drawback is lifting of child is very difficult by using gripping arm.

major problem faced by the human society was water scarcity which is analyzed by Bharathi and Suchitha. Due to drought and depletion of underground water, more bore wells are drilled on the surface of the earth. In many areas, the bore wells are drilled and left open without any proper covering. These bore wells became death pits and started taking many lives especially small children. Now a days falling of children in bore wells are increasing due to carelessness and playful activities of the children. The hole dug for the bore wells are deep around 700 feet. In these cases, the rescue of child from such deepest bore well is quite challenging

B.Bharathi describes the design of a robot for rescuing the child from bore well. This robot is capable of moving inside the bore well, according to the human comment by PC and also pick and place based on the arm design. This robot is operated through PC with the help of wireless Zigbee technology and wireless camera which gives both the audio and video signals on the TV. The high power LED in the robot acts as a light source in the pipe where the light intensity is low. It is a low cost human controlled robot used to monitor and gives an insight view of rescuing the child safely.

Palwinder Kaur describes the rescue operation without human intervention. Here the wheeled leg mechanism is designed to go inside the pipe and the legs are circumferentially and systematically spaced out apart. The robot can adjust its legs according to the pipeline dimensions. The robot has consisting of power supply, switch pad and gear motor. The child International Journal of Pure and Applied Mathematics Volume 119 No. 15 2018, 861-865 ISSN: 1314-3395 (on-line version) url: <http://www.acadpubl.eu/hub/> Special Issue <http://www.acadpubl.eu/hub/> 861 position is captured from the bore well with USB camera and monitored on PC. The LM35 temperature sensor and 16*2 LCD are interfaced with pic 16F877A microcontroller to sense and displays on LCD

Manish Raj describes as the diameter of the bore well is narrow for any adult person and light goes dark inside it, the rescue task in that situation is challenging. The robotic system which will attach a harness to the child using pneumatic arms for picking up. A teleconferencing system is also attached to the robot for communicating with the child.

John Jose Pattery describes the facility that monitors the trapped child, supplies the oxygen and provides a supporting platform to lift up the child. The first motor placed at top turns a gear mechanism which in turn pushes 3 blocks arranged at 120 degree from each other towards the side of the bore well. The bottom shaft is turned by 130 degrees with the help of second motor, thus helping to locate the gap through which the lifting rod is adjusted by third motor. When the diameter is adjusted, the forth motor helps the lifting rod to screw its way through the gap towards the bottom of the child. Once lifting the rid reaches a safe position under, an air compressor is operated to pump air to the bladder attached to the end of lifting rod through an air tube that runs downwards inside the lifting rod. The bladder provides a safe seating to the child. Them the first motor is reversely operated so as to unclamp the system. Simultaneously it is lifted out of the well using a chain or rope.



III.EXISTING SYSTEM

In India for past few days people are facing a distressed cruel situation like child have fell in the bore well and struck in the hole which is uncovered and getting trapped. Rescue of trapped child from bore well is very risky and difficult process when compared to the other accidents. It takes more than a day to save the child. There are so many rescue operations are there, but most of them are getting failed. In Previous days a parallel pit is digged it is more time taking process. Recently a Hand robot is designed to rescue the child but it also has some drawbacks. It can hold only the body it can'thold the hand or leg.

IV.PROPOSED SYSTEM

Child Rescue System used if a child falls in a bore-well. In this method a metal plate is placed at a distance below the entrance of the bore-well. IR technology is efficiently used to identify if a child has fallen in to a bore-well. Here, pair of IR sensors is placed in four directions. The IR transmitter and receiver are placed opposite to eachother in a line of sight propagation technique. The output of the IR sensors receiver is connected to a comparator. The output of the comparator is given the input pins of the microcontroller. Whenever both the pair of IR sensors line of sight communication is blocked only then the microcontroller sends an SMS via IOT to the child rescue center or to the police station. If one pair of IR sensors line of sight communication is obstructed then no SMS is sent by microcontroller via IOT. As soon as both the pair of IR sensor is blocked, then depending on the program embedded within the microcontroller the D.C motor connected to a metal lid/plate begins to block the passage of the bore well, thus preventing the child from further falling into the depths of the bore well. In the project demonstration LCD is used to display the working of every unit in this project

V.BLOCK DIAGRAM

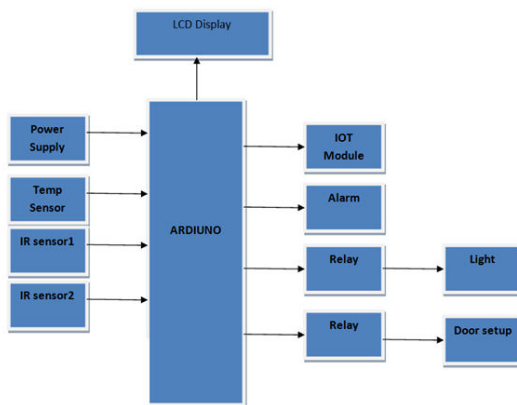

1. IR SENSOR

Infrared sensors are the most often used sensor by amateur robots. Understanding how they behave can help address many of your requirements and would suffice to address most of the problem statements for various robotics events in India. Be it a typical white/black line follower, a wall follower, obstacle avoidance, micro mouse, an advanced flavor of line follower like red line follower, etc, all of these problem statements can be easily addressed and granular control can be exercised upon your robots performance if you have a good operational understanding of Infra red sensors.

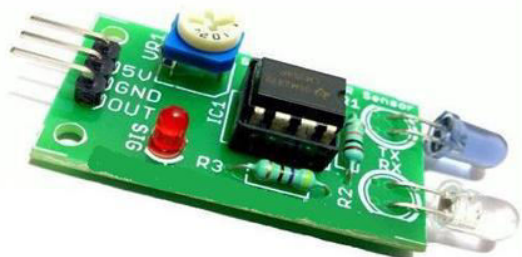

IR sensors are classified into different types depending on the applications. Some of the typical applications of different types of sensors are: The speed sensor is used for synchronizing the speed of multiple motors. The temperature sensor is used for industrial temperature control. PIR sensor is used for automatic door opening system and Ultrasonic sensor are used for distance measurement. Upon careful observation, you will notice that amongst the two 'legs', one has a much wider base within the diode. That is normally the cathode (negative) whereas the leg having a smaller base would be the anode (positive terminal). When the Tx is forward biased, it begins emitting infrared. Since it's not in visible spectrum, you will not be able to see it through naked eyes but you will be able to view it through an ordinary cell phone camera.

2. BUZZER

Buzzer or beeper is an audio signalling device. Buzzer will automatically turn on when alcohol is detected.



3. MOTOR

DC motor is used as a prototype to indicate the motion of the vehicle. When alcohol is detected we can slow it down to a certain speed by using pwm function when interfaced with Arduino using relay motor driving IC.



4. ESP8266 WIFI MODULE

The receiving internet records via ESP8266 modem when interfaced with microcontroller or PC is tons much less tough as differentiated and Ethernet module when you consider that ESP is a SoC and Integrated TCP/IP way of life stack. AT firmware is supplied convenient to use bearing set with which it will in accepted be orchestrated or labored at a variety of Baud Rate (Supported 9600, 115200 or 57600). Plain Text may additionally be despatched via the modem via interfacing solely three warning signs of the successive interface of modem with microcontroller (Tx, Rx and GND). In this arrangement RTS and CTS symptoms of successive port interface of ESP Modem are associated with one another. The transmit banner of successive port of microcontroller is associated with of the consecutive interface get sign (Rx) of ESP



Modem whilst get banner of microcontroller successive port is associated with transmit hail (TxD) of successive interface of ESP Modem.

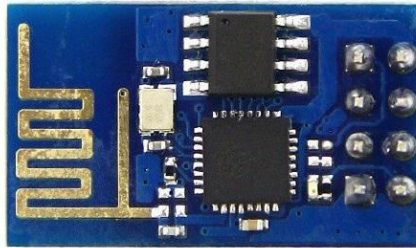

5. MICROCONTROLLER

Arduino Uno is primarily based on AVR microcontroller referred to as Atmega328. This controller comes with 2KB SRAM, 32KB of flash memory, 1KB of EEPROM. Arduino Board comes with 14 digital pins and 6 analog pins. ON-chip ADC is used to pattern these pins. A sixteen MHz frequency crystal oscillator is geared up on the board. Following parent indicates the pinout of the Arduino Uno Board.



Pin description

There are various I/O digital and analog pins positioned on the board which operates at 5V. These pins come with fashionable running scores ranging between 20mA to 40mA. Internal pull-up resistors are used in the board that limits the modern-day exceeding from the given running conditions. However, too lots enlarge in present day makes these resistors vain and damages the device.LED. Arduino Uno comes with built-in LED which is related thru pin thirteen Providing HIGH price to the pin will flip it ON and LOW will flip it OFF.Vin. It is the enter voltage supplied to the Arduino Board. It is unique than 5 V provided via a USB port. This pin is used to grant voltage. If a voltage is supplied via electricity jack, it can be accessed thru this pin.5V. This board comes with the capability to grant voltage regulation. 5V pin is used to furnish output regulated voltage. The board is powered up the usage of three approaches i.e. USB, Vin pin of the board or DC energy jack.USB helps voltage round 5V whilst Vin and Power Jack guide a voltage stages between 7V to 20V. It is endorsed to operate the board on 5V. It is vital to notice that, if a voltage is furnished thru 5V or 3.3V pins, they end result in bypassing the voltage law that can injury the board if voltage surpasses from its limit.GND. These are floor pins. More than one floor pins are supplied on the board which can be used as per requirement.Reset. This pin is integrated on the board which resets the application walking on the board. Instead of bodily reset on the board, IDE comes with a characteristic of resetting the board via programming.IOREF. This pin is very beneficial for supplying voltage reference to the board. A protect is used to examine the voltage throughout this pin which then pick the applicable strength source.PWM. PWM is furnished via 3,5,6,9,10, 11pins. These pins are configured to provided 8-bit output PWM.SPI. It is acknowledged as Serial Peripheral Interface. Four pins 10(SS), 11(MOSI), 12(MISO), 13(SCK) grant SPI verbal exchange with the assist of SPI library.AREF. It is referred to as Analog Reference. This pin is used for imparting a reference voltage to the analog inputs.TWI. It is known as Two-wire Interface. TWI verbal exchange is accessed via Wire Library. A4 and A5 pins are used for this purpose.Serial Communication. Serial conversation is carried out via two pins known as Pin zero (Rx) and Pin 1 (Tx).Rx pin is used to acquire information whilst Tx pin is used to transmit data.External Interrupts. Pin two and three are used for imparting exterior interrupts. An interrupt is known as by means of offering LOW or altering value.

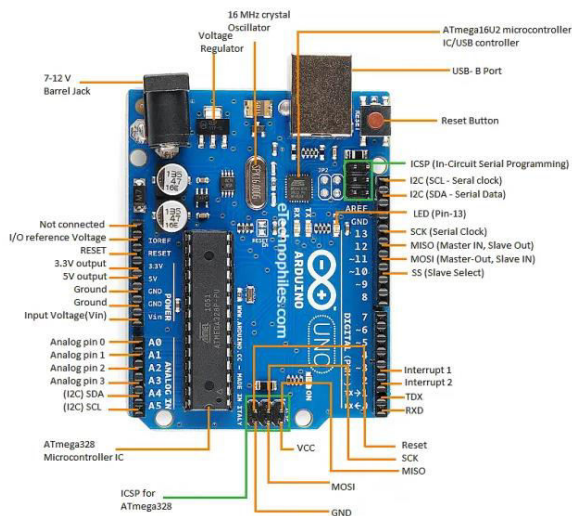

VI.RESULT

Child Rescue System used if a child falls in a bore-well. In this method a metal plate is placed at a distance below the entrance of the bore-well. IR technology is efficiently used to identify if a child has fallen in to a bore-well. Here, pair of IR sensors is placed in four directions. The IR transmitter and receiver are placed opposite to each other in a line of sight propagation technique. The output of the IR sensors receiver is connected to a comparator. The output of the comparator is given the input pins of the microcontroller. Whenever both the pair of IR sensors line of sight communication is blocked only then the microcontroller sends an SMS via IOT to the child rescue center or to the police station. If one pair of IR sensors line of sight communication is obstructed then no SMS is sent by microcontroller via IOT. As soon as both the pair of IR sensor is blocked, then depending on the program embedded within the microcontroller the D.C motor connected to a metal lid/plate begins to block the passage of the bore well, thus preventing the child from further falling into the depths of the bore well. In the project demonstration LCD is used to display the working of every unit in this project





VII.CONCLUSION

Child Rescue System used if a child falls in a bore-well. In this method a metal plate is placed at a distance below the entrance of the bore-well. IR technology is efficiently used to identify if a child has fallen in to a bore-well. Here, pair of IR sensors is placed in four directions. The IR transmitter and receiver are placed opposite to each other in a line of sight propagation technique. The output of the IR sensors receiver is connected to a comparator. The output of the comparator is given the input pins of the microcontroller. Whenever both the pair of IR sensors line of sight communication is blocked only then the microcontroller sends an SMS via IOT to the child rescue center or to the police station. If one pair of IR sensors line of sight communication is obstructed then no SMS is sent by microcontroller via IOT. As soon as both the pair of IR sensor is blocked, then depending on the program embedded within the microcontroller the D.C motor connected to a metal lid/plate begins to block the passage of the bore well, thus preventing the child from further falling into the depths of the bore well. In the project demonstration LCD is used to display the working of every unit in this project.

REFERENCES

- [1] B Bharathi, B Suchitha Samuel, Design and Construction of Rescue Robot and Pipeline Inspection Using Zigbee, International Journal of Scientific Engineering and Research , 1(2), 2013, 42-49.
- [2] PalwinderKaur, Ravinder Kaur, Gurpreet Singh, Pipeline Inspection and Bore Well Rescue Robot, International Journal of Research in Engineering and Technology, 2(5), 2014, 04-12.
- [3] K Saran, S Vignesh, Marlon Jones Louis, Bore-well Rescue Robot, International Journal of Research Aeronautical and Mechanical Engineering, 1(4), 2014, 61-80.
- [4] VVenmathi, E Poorniya, S Sumathi, Borewell Rescue Robot, International Journal of Computer Applications, 1(3), 2015, 14-23. [5] John Jose pottery, "robot for bore well rescue", amaljothi college of engineering, vol. 10, Jun 2009.
- [5] S. Gopinath, T. Devika, L. Manivannan, N. SuthanthiraVanitha, "Rescue Child from Bore well using Embedded System", 2015.
- [6] V. Venmathi, E. Poorniya, S. Sumathi, "Borewell Rescue Robot", International Journal of Computer Applications, vol. 113, no. 14, 2015.
- [7] C.N. Sakhale, 2D.M. Mate, 3Subhasis Saha, TomarDharmal, PranjitKar, Arindam Sarkar, Rupam Choudhury, Shahil Kumar, "An Approach to Design of Child Saver Machine for Child Trapped in Borehole", International Journal of Research in Mechanical Engineering, pp. 26-38, October-December 2013.
- [8] Shuhai Wang, G. Gowtham, G. Venkatachalam, S. Narayanan, "School of Mechanical Building Sciences" in Design and Simulation of Bore well rescue robot- Advanced ARPN Journal of Engineering and Applied Sciences, India:VIT University, MAY 2014.



INNO SPACE
SJIF Scientific Journal Impact Factor
Impact Factor
7.54

ISSN

INTERNATIONAL
STANDARD
SERIAL
NUMBER
INDIA



INTERNATIONAL JOURNAL OF MULTIDISCIPLINARY RESEARCH IN SCIENCE, ENGINEERING AND TECHNOLOGY

| Mobile No: +91-6381907438 | Whatsapp: +91-6381907438 | ijmrset@gmail.com |

www.ijmrset.com