



e-ISSN:2582-7219



INTERNATIONAL JOURNAL OF MULTIDISCIPLINARY RESEARCH IN SCIENCE, ENGINEERING AND TECHNOLOGY

Volume 6, Issue 6, June 2023



INTERNATIONAL
STANDARD
SERIAL
NUMBER
INDIA

Impact Factor: 7.54



6381 907 438



6381 907 438



ijmrset@gmail.com



www.ijmrset.com



Dynamic Analysis of G+50 Building Having Outrigger and Tube in Tube System

Gauri G. Lasankar ¹, Prof. V.M. Sapate²

PG scholar, M. Tech. Structural Engineering, Department of Civil Engineering, G.H.Raisoni University,
Amravati, India ¹

Assistant Professor, Department of Civil Engineering, G.H.Raisoni University, Amravati, India ²

ABSTRACT - Nowadays, the building height is observed more and more slender, and more susceptible to sway and hence dangerous in the earthquake. Such type of the building can be strengthening by providing an appropriate lateral load resisting system. In the seismic design of the buildings, reinforced concrete structural walls or shear-wall, act as major earthquake resisting members. Structural walls provide an efficient bracing system and offer great potential for lateral load resistance. The properties of these seismic shear-walls dominate the response of the buildings and therefore, it was important to evaluate the seismic response of the walls appropriately. In this study the (G+50) storey building was analyze with different effective and economical system which can resist wind load and seismic load. Based on literature review, an attempt has been made to compare various lateral load resisting systems such as Shear wall, Outrigger, Frame tube system etc using ETABS Software

KEYWORDS: Shear wall, Outrigger, tube system, ETABS

I. INTRODUCTION

In the recent days, major cities are experiencing the shortage of land due to growing population which leads to increase in construction of tall buildings and in the other hand in view of economic power there is competitiveness in mankind to have the tallest building which make the way of opportunities in the building profession. As these tall building are critical to resist lateral loads structural engineer has been challenged to meet drift requirement and to minimize the effect. Due to limited area and the increasing expansion of urbanization it is feasible to expand in vertical direction than in horizontal direction. And due to increasing vertical urbanization it is important to adopt to more stable structure.

1.1 Tube System

Tube System For tall buildings, use of braced frames and structural walls alone (even though of reasonably sized members) may be insufficient to control their overall lateral displacement as well as the force demands on various structural members. In such cases, more rigid structural systems are required, like Tube, Tube-in-Tube and Bundled Tube systems, depending on the size and loads on the building. Closely-spaced heavy columns forming a closed loop inter-connected with beams, together called the tube, forms the first part of the lateral load resisting system. Heavy reinforced concrete structural walls together creating a closed shaft, called as the core, form the other part. The Tube System consists of one perimeter tube with a central core.

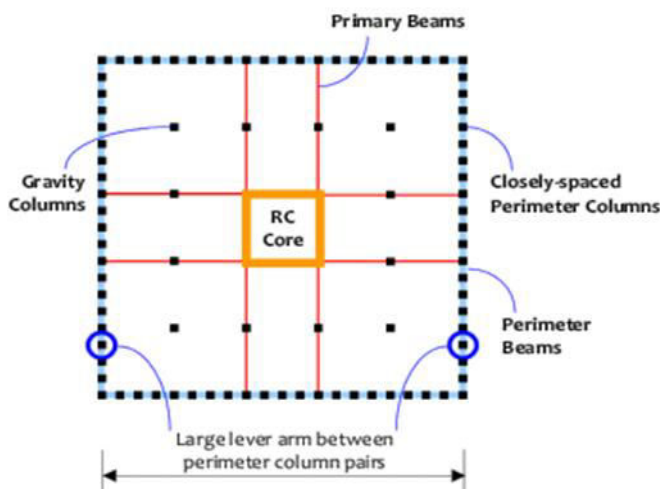

Fig 1.1 Structural Elements in a Tube System: Some columns (called Gravity Columns) are not necessarily connected with beams to either the Core or the Tube.

Tube-in-Tube and Bundled Tube Systems:

When the plan size of the building increases, additional columns may be required to support the gravity loads between the outer tube and inner core, and prevent the slab from bending too much. These columns are not part of the main lateral load resisting system, and therefore are not intended to carry any lateral loads; they are called gravity columns.

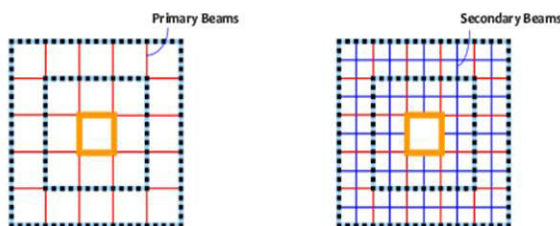

Fig 1.2 Beams in Tube-in-Tube Systems: Secondary beams help in transferring the gravity loads to the two tubes and the core.

1.2 Outriggers

The outriggers serve to reduce the overturning moments in shear wall otherwise it will act as a pure cantilever. Outriggers were proved in history with respect to structural style and efficiency. The outriggers are connected from central core wall to exterior columns the core wall may be centrally located or at the side of the building. The direct connection between central core wall to exterior columns by connecting strong stiff outriggers is called conventional outrigger system and if the floor diaphragms are used to connect exterior columns to central core wall, using outrigger around the exterior of building then it is called virtual outrigger system.

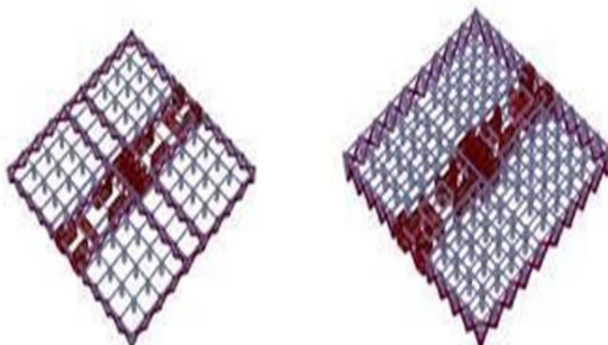

Fig 1.3 Conventional outrigger system and Virtual outrigger system



1.3 Shear Wall

Shear walls are vertically oriented members in addition to slabs, beams and columns, capable of resisting the lateral loads. They start at the foundation and run throughout the height of the building. The thickness of the shear walls vary from 150mm to 400mm depending on the height of the building. RCC shear wall has high in plane stiffness, at the same time resist massive horizontal masses and support gravity masses in the direction of orientation of the walls, thereby serving advantageous in many Structural Engineering applications and reducing the risk of damage in structure. In this study, a reinforced concrete structure with shear walls at various locations is analyzed and the optimum position of the shear walls has been studied.

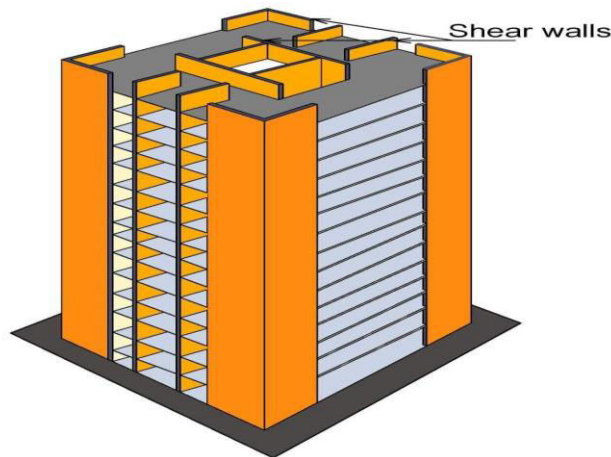

Fig 1.5 Building with Shear wall

1.4 Aim

To find global moments, base shear, time period, drift and displacement for different lateral load resisting systems in high rise building

1.5 Objectives

- Comparative analysis of multistoried OMRF and RCC building tube in tube structure and moment resisting structure with static and dynamic loads in high seismic zones.
- To study behavior of tubular structure for different column spacing.
- Results are compared in terms of Base shear, Displacement, Drift, Time period & global moments.

II. METHODOLOGY

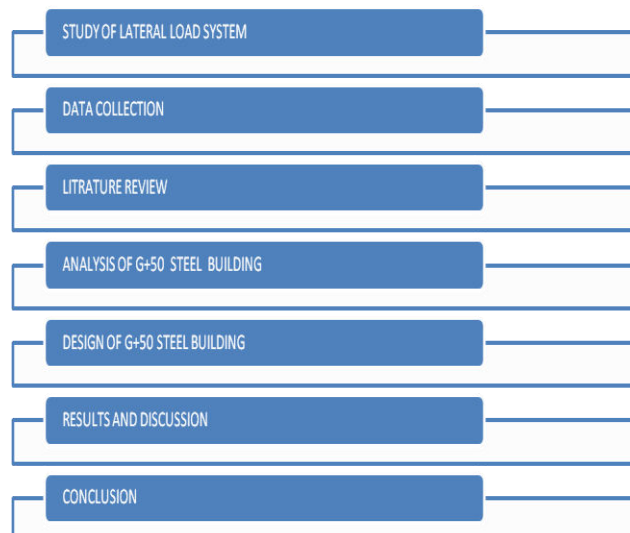



2.1 Software Information (ETABS)

ETABS is a sophisticated, yet easy to use, special purpose analysis and design program developed specifically for building systems. ETABS 2016 features an intuitive and powerful graphical interface coupled with unmatched modeling, analytical, design, and detailing procedures, all integrated using a common database. Although quick and easy for simple structures, ETABS can also handle the largest and most complex building models, including a wide range of nonlinear behaviors necessary for performance based design, making it the tool of choice for structural engineers in the building industry.

III. PROBLEM STATEMENT

Table 5.1 Problem Statement

Number of Stories	50
Total Height Of building	150 m
Height of Each Stories	3 m
Dimension of building	90 m x 70 m
Size of Beam	Primary- ISMB 500, Secondary- ISMB 450
Size Of Column	ISMB 600
Slab Thickness	S150 mm
Shear Wall Thickness	W200 mm
Outrigger at	1st,10th,20th,30th,40th,50th floor
Location	Pune
Seismic Zone	Zone IV
Basic Wind Speed	39 Km/h
Response Reduction Factor	5.0
Importance Factor	1
Grade Of Concrete	M 30
Grade Of Reinforcing Steel	F500
Density Of Concrete	25 KN/m ³
Supports at base	Fixed
Diaphragm	Rigid
Load Description	DL-Dead Load LL-Live load SDL- Super Dead load EQX- Earthquake in X direction EQXN- Earthquake in X Negative direction EQY- Earthquake in Y direction EQYN- Earthquake in Y Negative direction Time History- Time History Data of Bhuj
Load Combinations	1.7 DL + LL 1.7DL +/- EQ 1.7DL +/- WL 1.3DL + LL +/- EQ 1.3DL + LL +/- WL 0.9DL +/- 1.7EQ 0.9DL +/- 1.7WL 1.7*DL+/- Time History 1.3*DL + LL +/- Time History



3.2.1 Model 1 - With Shear Wall

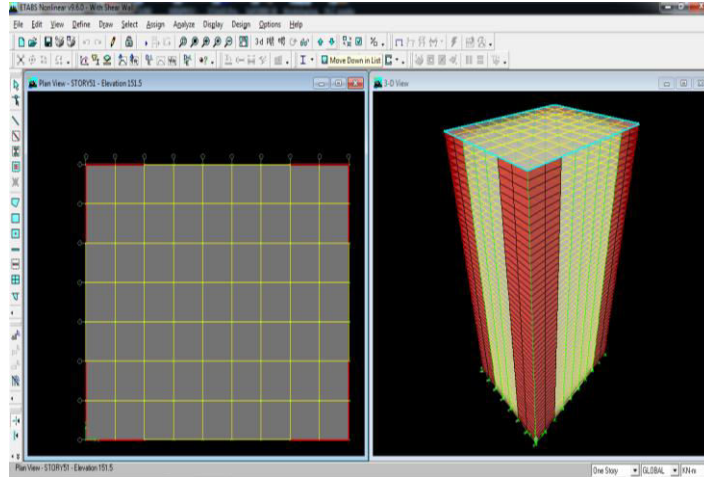

3.2.2 Model 2 – With Outrigger System

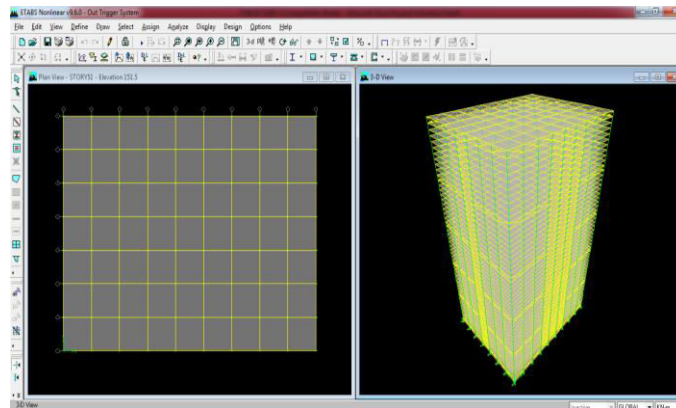

3.2.3 Model 3 – Tube System

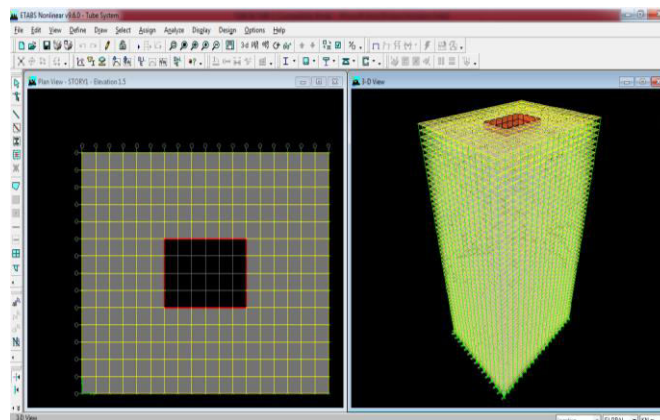



IV. RESULTS AND DISCUSSION

4.1 Building With Shear Wall:-

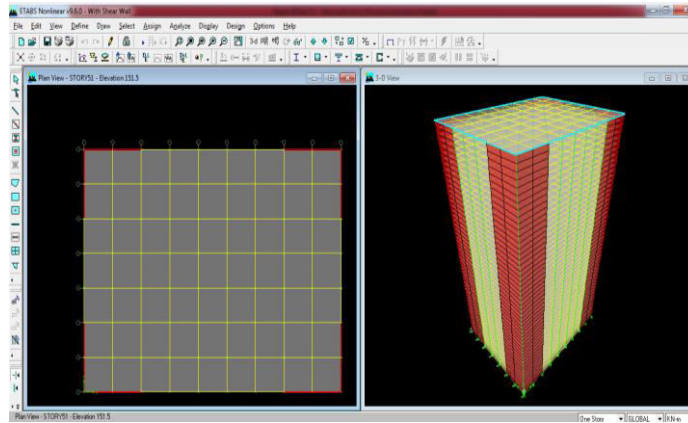
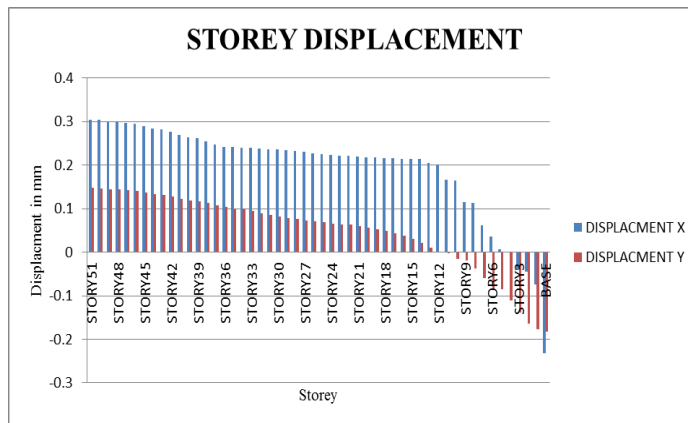
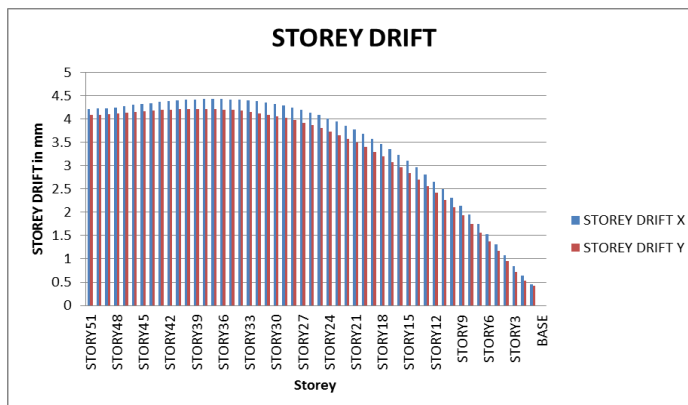

Fig 5.1 Modeling in ETABS With shear wall



Graph 5.1 Storey Displacement in X and Y with shear wall



Graph 5.2 Storey Drift in X and Y with shear wall

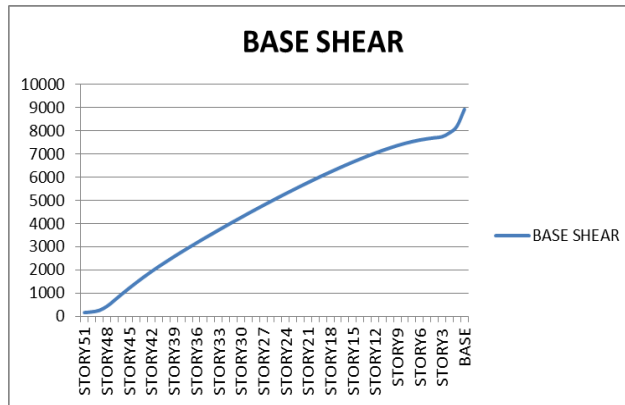

Graph 5.3 Base shear with shear wall

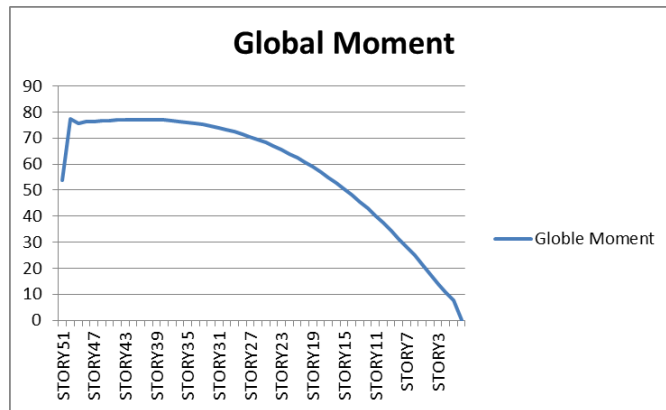

Graph 5.4 Global Moments with shear wall

4.2 TIME PERIOD

4.5.1 Building with Shear Wall

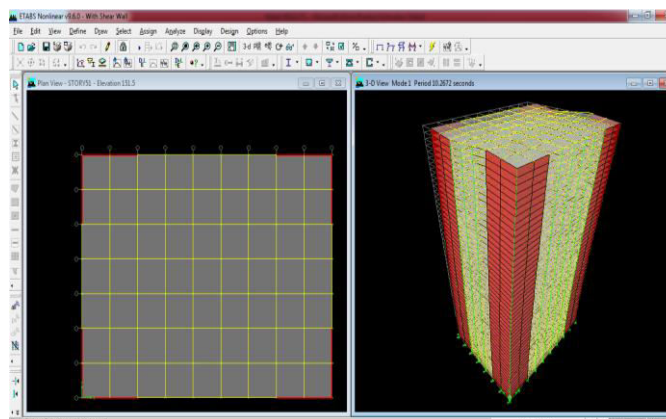

Fig 4.2.1 Time Period for Mode 1

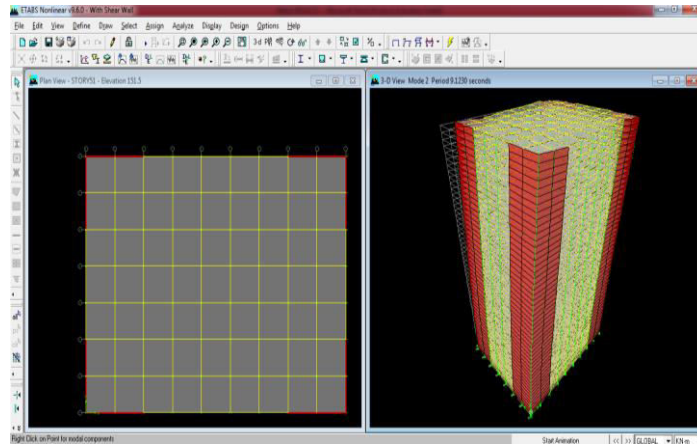

Fig 4.2.2 Time Period for Mode 2

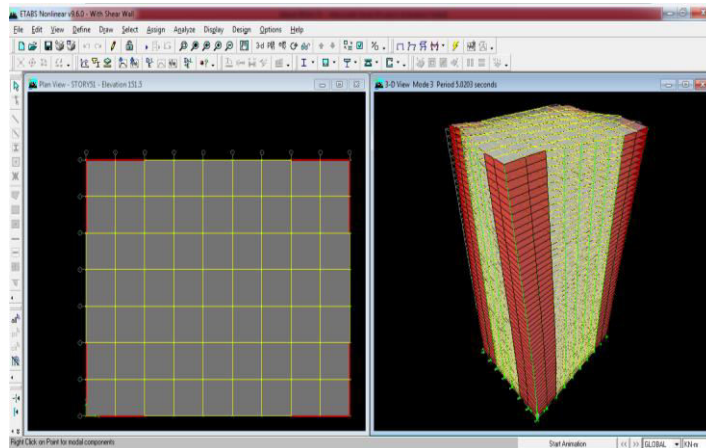

Fig 4.2.3 Time Period for Mode 3

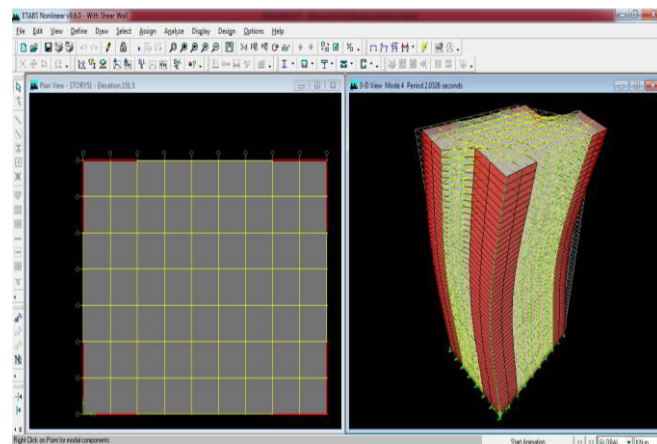
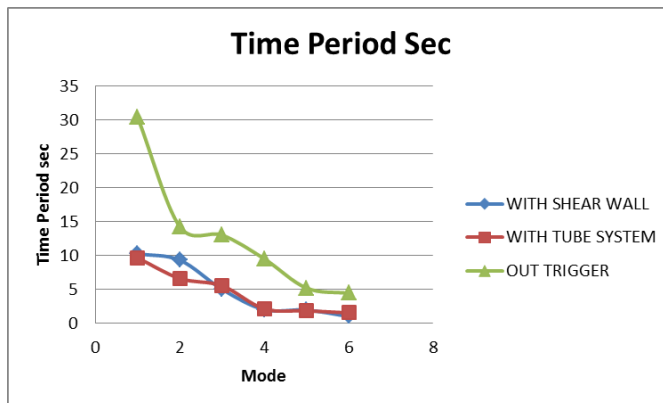

Fig 4.10 Time Period for Mode 4



Graph 4.2.1 Comparison Time Period

V. CONCLUSION

STOREY DISPLACEMENT:

- The Storey Displacement in X direction with three cases. Displacements without trigger are 2.84 at top. And with shear wall 0.3668 and with tube system displacement is 0.1125. As compare to shear wall , tube system is increased by 20-30% and as compare to tube system, out trigger is increased by 35-40 %
- The Storey Displacement in Y direction with three cases. Displacements without trigger are 2.33. And other with shear wall 0.17 and with tube system displacement is 0.011. As compare to tube system, shear wall is increased by 40-45%, And As compare to shear wall, out trigger is increased by 50-52 %

STOREY DRIFT:

- The Storey Drift in X direction with three cases. Out trigger system storey drift is 7.06 and tube system is 2.22 and with shear wall is 4.21. As compare to tube system, shear wall is increased by 45-48% and As compare to shear wall, out trigger is increased by 40-45 %
- The Storey Drift in Y direction with three cases. Out trigger system storey drift is 7.06 and tube system is 2.22 and with shear wall is 4.21. As compare to tube system, shear wall is increased by 45-50 % and as compare shear wall, out trigger is increased by 50-55 %

BASE SHEAR:

- The above graph represents the Base Shear of three cases. Out trigger system Base Shear is 159.95 and tube system is 900.06 and with shear wall is 2256.9. As compare to Out trigger, tube system is increased by 60-70% and As compare to tube system , shear wall is increased by 70-75%

GLOBAL MOMENTS:

- The above graph represents the Global Moments of three cases. Out trigger system Global Moment is 87.26 and tube system is 88.87 and with shear wall is 70.79. As compare to shear wall, out trigger is increased by 10-15%, And As compare to out trigger, tube system is increased by 9-13 %

TIME PERIOD

- The Time Period of three cases. Out trigger system Time Period is 30.44 and tube system is 9.66 and with shear wall is 10.26. As compare to tube system, shear wall is increased by 30-35% and as compare to shear wall, out trigger is increased by 35-40%

REFERENCES

- 1) Shubham P. Dhoke “Comparative Analysis of Different Lateral Load Resisting System for RCC Structure” ISSN Vol. 6, Issue 4, April 2017
- 2) TejParkar “Review on Behavior of Lateral Load Resisting System for High-Rise Building” ISSN NO: 2249-7455 Volume IX, Issue I, JANUARY/2019
- 3) Khuzaim J. Sheikh “A Review on Study Of Lateral Load Resisting Systems In Tall Structures” (SJIF): 4.72 Volume 4, Issue 11, November -2017
- 4) ArafahElhelloty “Effect of Lateral Loads Resisting Systems on Response of Buildings Subjected to Dynamic Loads”ISSN: 2319-6491Volume 6, Issue 10 [October. 2017]
- 5) S .VijayaBhaskar Reddy “Study of Lateral Structural Systems in Tall Buildings” ISSN 0973-4562 Volume 13, Number 15 (2018)



- 6) Janakkumar M. Mehta “Comparative Study on Lateral Load Resisting System in High-Rise Building using ETABS” (IJETT) – Volume 47 Number 2 May 2017
- 7) AbhijeetBaikerikar “Study of Lateral Load Resisting Systems of Variable Heights in All Soil Types of High Seismic Zone” EISSN: 2319-1163 Volume: 03 Issue: 10 | Oct-2014
- 8) BorkanMoatasemMutashar “A Study on Optimisation of Lateral Load Resisting Systems (Outrigger, Diagrid, and Tube-In-Tube) by SAP 2000” ISSN 2319-8885 Vol.05,Issue.10, May-2016
- 9) Divya C. Bhuta “Comparative Study on Lateral Load Resisting System in Tall Building” IJSTE Volume 2 | Issue 11 | May 2016
- 10) Shrinivas. M R “To Study The Performance Of High-Rise Building Under Lateral Load With Bare Frame And Shear Wall With Openings” (IRJET) Volume: 05 Issue: 05 | May-2018



INNO SPACE
SJIF Scientific Journal Impact Factor
Impact Factor
7.54

ISSN

INTERNATIONAL
STANDARD
SERIAL
NUMBER
INDIA



INTERNATIONAL JOURNAL OF MULTIDISCIPLINARY RESEARCH IN SCIENCE, ENGINEERING AND TECHNOLOGY

| Mobile No: +91-6381907438 | Whatsapp: +91-6381907438 | ijmrset@gmail.com |

www.ijmrset.com