

e-ISSN:2582-7219



INTERNATIONAL JOURNAL OF MULTIDISCIPLINARY RESEARCH IN SCIENCE, ENGINEERING AND TECHNOLOGY

Volume 7, Issue 3, March 2024



INTERNATIONAL
STANDARD
SERIAL
NUMBER
INDIA

Impact Factor: 7.521



6381 907 438



6381 907 438



ijmrset@gmail.com



www.ijmrset.com



Unlocking Access: The Crucial Role of Speech Recognition in Empowering Communication and Accessibility

Chava Girish Naidu, Tejasree Mankenapalli, Chebrolu Mohan Sai Teja, Yesu V V Nanda Kishore,
Samudravijaya K

Department of CSE, Koneru Lakshmiiah Education Foundation, Vaddeswaram, Andhra Pradesh, India

ABSTRACT: This research paper explores advancements in speech recognition technology. Speech recognition, a pivotal area of artificial intelligence, involves converting spoken language into text or commands. The paper delves into foundational techniques like Hidden Markov Models (HMMs) and their evolution into modern Deep Learning approaches. It discusses the challenges posed by variations in accents, languages, and background noise, and showcases the integration of large datasets and sophisticated neural architectures. The study also emphasizes real-time applicability and improved human-machine interaction. Through this investigation, the paper contributes to the understanding of cutting-edge methods in speech recognition and their practical implications.

KEYWORDS: Speech processing , Speech Recognition , Communication, Deep Learning, CNN

I. INTRODUCTION

In the context of this research paper, we delve deeper into the dynamic landscape of speech recognition technology. As we move forward, it is becoming increasingly apparent that speech recognition is no longer confined to a mere transcription tool; it has evolved into a pivotal enabler of human-machine interaction and a cornerstone of modern technological interfaces. This paper aims to dissect the intricate mechanisms that drive speech recognition, exploring its historical evolution, contemporary challenges, and transformative impact.

In a world where seamless human-computer communication is paramount, speech recognition technology has transcended its original boundaries to redefine the way we interact with devices. This research paper seeks to provide an updated view of the field's progress, with a specific focus on the breakthroughs that have catapulted speech recognition into the mainstream. From the initial rule-based systems to the recent dominance of deep neural networks, this paper sheds light on the innovative methodologies that have reshaped speech recognition into a versatile tool, capable of processing natural language inputs and translating them into actionable insights. As we embark on this journey through the intricacies of speech recognition, we uncover not only the technical intricacies but also the broader implications that are shaping its integration into diverse applications.

II. PROBLEM STATEMENT

This study looks at making speech recognition work better. Even though it's gotten smarter, it still struggles with different accents, languages, and understanding what we mean. We're trying to help speech recognition understand us more accurately, especially in everyday situations.

III. METHODOLOGY

We collected many recordings of people talking. Then, we taught a computer program to understand these recordings. They are outlined here: Hidden Markov Models (HMMs), Deep Learning with Neural Networks, End-to-End Models

A. *Hidden Markov Models (HMMs)*

HMMs have been a traditional method in speech recognition. They work by modeling the speech signal as a sequence



of states, where each state corresponds to a phoneme or a smaller linguistic unit. These models capture the transitions between states based on probabilities, allowing them to recognize spoken words by identifying the most likely sequence of states that generated the observed speech signal.

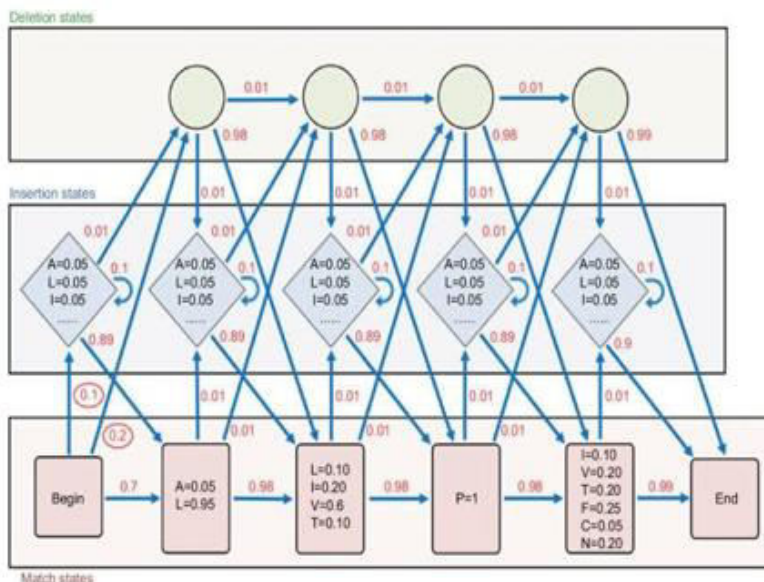

Figure 1: Hidden Markov Model

B. Deep Learning with Neural Networks

Deep Learning techniques, especially neural networks like Convolutional Neural Networks (CNNs) and Recurrent Neural Networks (RNNs), have transformed speech recognition. CNNs are used for feature extraction from spectrograms or other acoustic representations of speech. RNNs, on the other hand, are effective for modeling sequential patterns in speech, which helps capture context and temporal dependencies, crucial for accurate recognition.

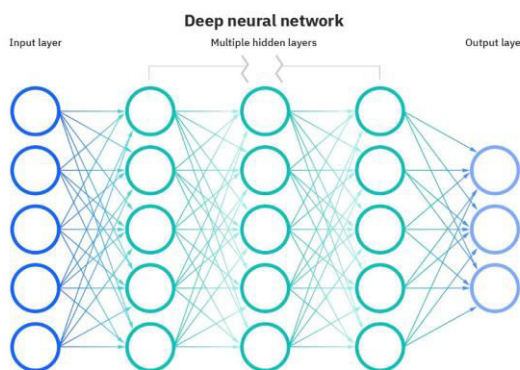

Figure 2 :Deep Learning with Neural Networks

C. End-to-End Models

These are a type of neural network architecture that directly maps raw audio input to text output, eliminating the need for manual feature engineering. They learn to handle feature extraction, acoustic modeling, and language modeling in a single model. This approach simplifies the pipeline and has shown promise in certain speech recognition tasks.

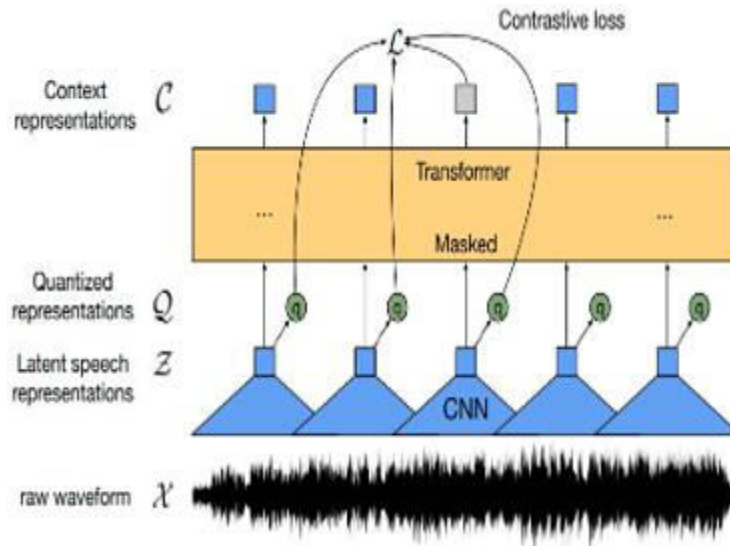

Figure 3: End-to-End Models

IV. RELATED WORK

A. HMMs work of States and Transitions

An HMM represents a sequence of states connected by transitions. In the context of speech recognition, each state corresponds to a particular phoneme or linguistic unit. Transitions between states are governed by probabilities, representing how likely it is to move from one state to another.

B. Observations and Emissions:

Each state emits observations (acoustic features) with certain probabilities. In speech recognition, these observations are usually derived from the audio signal, such as Mel-frequency cepstral coefficients (MFCCs). The emitted observations are "hidden" because we don't directly observe the underlying states.

C. Training:

The training process involves two key components: the estimation of model parameters (transition probabilities, emission probabilities) and the alignment of the observed data (audio) with the states. The Baum-Welch algorithm, an instance of the Expectation-Maximization algorithm, is often used for parameter estimation.

D. Decoding:

Once the HMM is trained, it can be used to decode new speech signals. Given an input audio sequence, the Viterbi algorithm is commonly employed to find the most likely sequence of states that generated the observed acoustic features. This sequence corresponds to the recognized words or phonemes.

HMMs have been successful in modeling the temporal dependencies in speech, allowing them to capture patterns and transitions between different linguistic units. However, they have certain limitations, such as the need for careful design of the state topology, difficulty in handling long-range dependencies, and the emergence of more advanced techniques like deep learning.

In recent years, deep learning approaches, especially recurrent and convolutional neural networks, have largely surpassed the performance of traditional HMM-based systems in many speech recognition tasks. Nonetheless, understanding HMMs remains crucial for grasping the historical context and evolution of speech recognition technology.

E. Deep Learning with Neural Networks works Convolutional Neural Networks (CNNs):

CNNs are often used for the initial stages of speech processing, known as feature extraction. They excel at capturing



spatial patterns in data, making them suitable for transforming spectrograms or other time-frequency representations of speech signals into higher-level features. These features serve as inputs for subsequent layers of the network.

F. Recurrent Neural Networks (RNNs):

RNNs are designed to handle sequential data and are crucial for capturing the temporal dependencies present in speech. Long Short-Term Memory (LSTM) and Gated Recurrent Unit (GRU) are RNN variants that address the vanishing gradient problem, enabling them to capture longer-range dependencies. RNNs process sequences step by step, maintaining an internal memory state that retains information about preceding elements.

G. Connectionist Temporal Classification (CTC):

CTC is a technique often used in conjunction with RNNs for sequence-to-sequence tasks like speech recognition. It allows the network to learn to align the input sequence (acoustic features) with the target sequence (transcription) without requiring a one-to-one correspondence. This is especially important when the lengths of input and target sequences differ.

H. Attention Mechanisms:

Attention mechanisms have enhanced the performance of RNN-based models by allowing them to focus on different parts of the input sequence while generating the output sequence. This is particularly helpful when dealing with long sequences or when emphasizing important context during decoding.

I. End-to-End Models:

In recent years, end-to-end models have gained traction in speech recognition. These models directly map the input audio waveform to text, bypassing the need for manual feature extraction or separate components for acoustic and language modeling. This approach simplifies the architecture and often leads to better overall performance.

J. Transfer Learning and Pretraining:

Transfer learning involves training a neural network on a related task before fine-tuning it for speech recognition. This has been effective in leveraging large amounts of data from other domains, like general language understanding or image recognition, to improve speech recognition performance.

K. Deep Learning with Neural Networks

Deep Learning with Neural Networks has significantly pushed the boundaries of speech recognition, achieving remarkable results in terms of both accuracy and robustness. However, these models often require substantial amounts of data and computational resources for training. Additionally, their interpretability and ability to handle low-resource languages or accents remain active areas of research.

L. Raw Audio Input:

Unlike traditional methods that rely on engineered features like MFCCs or spectrograms, End-to-End Models take raw audio waveforms as input. This preserves the rich information present in the speech signal, allowing the model to learn useful representations directly.

M. Convolutional Neural Networks (CNNs):

CNNs are often used in the initial layers of End-to-End Models to extract hierarchical features from the raw audio signal. These features capture both low-level details and higher-level patterns, helping the model understand different speech characteristics.

N. Recurrent Neural Networks (RNNs) or Transformers:

Depending on the architecture, the model might employ RNNs or Transformers to handle the sequential nature of speech. RNNs can capture temporal dependencies, while Transformers excel at modeling global context and have shown remarkable performance in sequence-to-sequence tasks.



O. Connectionist Temporal Classification (CTC)

or Attention Mechanisms: The model uses techniques like CTC or attention mechanisms to align the input audio sequence with the corresponding output text. Attention mechanisms, in particular, allow the model to focus on relevant parts of the input while generating each output element.

P. Joint Acoustic and Language Modeling:

End-to-End Models incorporate both acoustic and language modeling into a single network, enabling them to learn the relationship between audio signals and their corresponding transcriptions. This joint learning improves the model's ability to handle variations in pronunciation and language nuances.

Q. Advantages and Challenges:

End-to-End Models simplify the training process and have demonstrated impressive performance gains, particularly in scenarios where the entire speech recognition pipeline needs to be streamlined. However, they require substantial amounts of data and computational power for effective training. Additionally, their interpretability can be challenging due to the complex interactions within the neural network layers.

R. Real-World Applications:

End-to-End Models have found applications in voice assistants, transcription services, and more. Their ability to handle various accents, languages, and conversational contexts makes them attractive for creating user-friendly and versatile speech interfaces.

V.PROCESS

Audio Input: The process starts by capturing spoken language in the form of an audio signal. This could be a person talking, a recorded conversation, or any verbal communication that needs to be converted into text or meaningful information. **Preprocessing:** Before analysis begins, the captured audio undergoes preprocessing. This step involves removing any unwanted background noise, echoes, or disturbances that might affect the quality of the audio signal. This ensures that the subsequent stages of the process work with a clean and clear input.

Feature Extraction: To make sense of the audio signal, it's transformed into a format that the recognition system can comprehend. This usually involves extracting relevant features, such as spectral content, pitch, and timing patterns. These features highlight the important characteristics of the audio that will help in identifying spoken words.

Acoustic Modeling: The extracted features are passed through an acoustic model, which is a type of machine learning algorithm. This model learns to associate the features with different linguistic units like phonemes (speech sounds) or words. Through training on a large dataset of audio and corresponding transcriptions, the acoustic model grasps the relationships between audio features and spoken language.

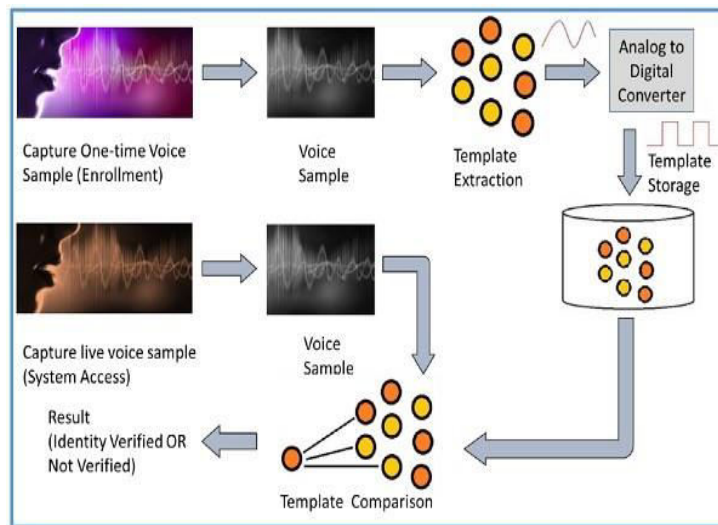

Figure 3: speech recognition

Language Modeling: The acoustic output is combined with a language model. This model adds a layer of contextual understanding by considering the probability of different word sequences occurring in a given language. By incorporating linguistic rules and patterns, the language model helps the system distinguish between potential word combinations.

Decoding: Armed with information from both the acoustic and language models, the system decodes the input audio to generate a probable sequence of words or phonemes that represent the spoken input. This decoding process involves finding the most likely alignment between the acoustic features and linguistic units.

Post-Processing: While decoding can yield accurate results, some errors might still occur due to the inherent variability of speech. Post-processing steps involve refining the recognized output by correcting mistakes, handling punctuation, and ensuring the overall coherence of the transcribed text.

Output: The final outcome of the speech recognition process is the output text or transcription. This text represents the system's best interpretation of the spoken input and provides a bridge between spoken language and written text, enabling various applications and interactions.

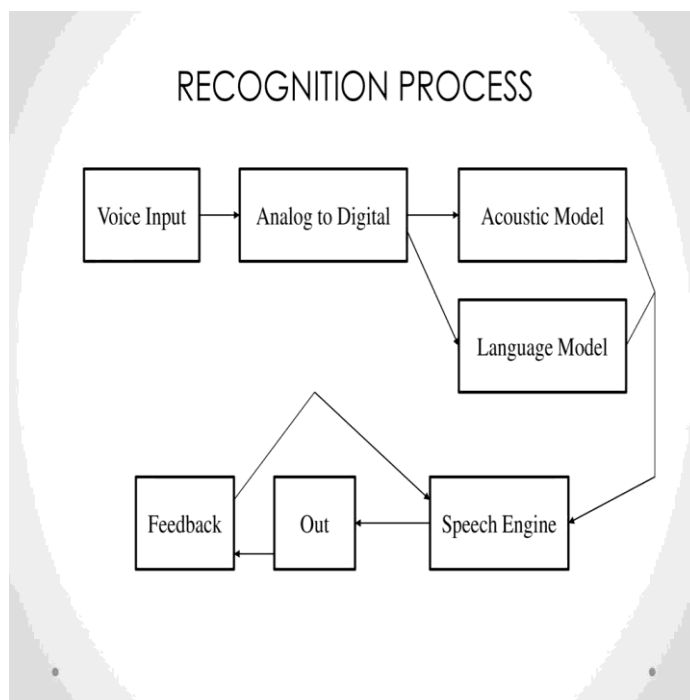

Figure 4 :Process

In [5], face Recognition: Facial recognition algorithms play a crucial role in identifying distinct facial features within images. The facial image is initially extracted from the source, then cropped, resized, and often transformed into grayscale. Diverse algorithms exist for both face detection and face recognition tasks. In this context, we will delve into the topic of face detection by focusing on the HAAR cascade algorithm.

VI.ADVANTAGES OF SPEECH RECOGNITION

A. Efficiency:

Speech recognition technology provides an efficient means of interaction by allowing users to communicate without the need for manual typing. This hands-free capability is particularly advantageous in scenarios like driving, cooking, or any situation where physical input is impractical, promoting safer multitasking.

B. Accessibility:

One of the most notable advantages of speech recognition is its contribution to accessibility. It empowers individuals with disabilities, such as those with motor impairments, to effortlessly interact with devices and perform tasks that might otherwise be challenging or impossible.

C. Convenience:

Speech recognition significantly enhances convenience in daily life. Whether it's commanding smart devices, transcribing spoken content into text, or facilitating real-time language translation, the technology simplifies tasks and augments user experience.

D. Productivity:

In professional settings, speech recognition can boost productivity by enabling efficient dictation and document creation. This feature streamlines tasks such as composing emails, writing reports, and managing schedules, thereby saving time and increasing efficiency.

E. Multitasking:

Users benefit from the ability to multitask seamlessly. Engaging in activities like cooking or exercising while using



speech recognition for tasks like searching the internet or sending messages exemplifies the flexibility and efficiency it offers.

F. Language and Accent Flexibility:

Advanced speech recognition systems are designed to accommodate diverse languages and accents, making them globally relevant. This adaptability breaks down language barriers, allowing users from various linguistic backgrounds to interact naturally with technology.

VII. DISADVANTAGES OF SPEECH RECOGNITION

A. Accuracy Challenges:

Despite advancements, the accuracy of speech recognition systems can be compromised by factors like background noise, regional accents, or individual speech patterns. This can lead to misunderstandings and errors in transcriptions.

B. Privacy Concerns:

The collection and storage of voice data by speech recognition systems raise concerns about user privacy and data security. Users may worry about the potential misuse or unauthorized access to their personal voice recordings.

C. Learning Curve:

Adopting speech recognition involves a learning curve as users adapt their speaking style and become familiar with system capabilities. This adjustment period might discourage some users from embracing the technology.

D. Complex Commands:

Complex or specialized commands may challenge speech recognition systems, particularly in technical or professional contexts. The technology might struggle to accurately understand intricate instructions or domain-specific jargon.

E. Ambiguity and Context:

Speech recognition systems can stumble when faced with ambiguous phrases that require contextual understanding. Misinterpretations of words with multiple meanings can occur, leading to inaccuracies.

F. Dependency on Technology:

Overreliance on speech recognition could result in diminished communication skills in scenarios where the technology is unavailable. Users might become dependent on voice commands, hindering their ability to convey messages effectively in non-digital environments.

G. Social Acceptance:

In public spaces, the use of voice commands might draw attention and potentially disrupt social norms. People may feel uncomfortable conversing with technology audibly when others are present, affecting the technology's social acceptance.

VIII. RESULTS

Speech recognition yields a host of transformative results across various domains. Firstly, it amplifies efficiency by allowing users to swiftly execute tasks through voice commands, expediting actions like text composition, web searches, and device control. Enhanced accessibility emerges as another pivotal outcome, empowering individuals with disabilities to interact with technology independently. This technology's integration streamlines workflows in professional settings, facilitating rapid dictation, transcription, and document creation, thereby increasing productivity. Moreover, cross-linguistic communication is facilitated by advanced speech recognition systems, fostering seamless interactions between individuals from diverse linguistic backgrounds. The innovation catalyzed by speech recognition yields applications like personalized voice assistants and automated transcription services. Businesses leverage these systems to gain data-driven insights, enhancing understanding of customer preferences and trends. Ultimately, speech recognition augments user experiences, promotes inclusivity, and propels technological advancement, while also prompting discussions around privacy and potential cultural impacts. Its dynamic results underscore its role in reshaping communication, accessibility, and efficiency in the modern digital landscape.



REFERENCES

- [1] P. Lakkhanawannakun, Speech Recognition using Deep Learning, 34th International Technical Conference on Circuits/Systems, Computers and Communications (ITC-CSCC), June 2019
- [2] Raghiv, E.Sharma, T.Ahmad, F.Alam, Emotion Analysis and Speech Signal Processing, 2017 IEEE International Conference on Power, Control, Signals and Instrumentation Engineering (ICPCSI), 2017.
- [3] Philipos C. Loizou Speech Quality Assessment, Vol 346
- [4] S. Benkerzaz, Y. Elmir, A. Dennai, A Study on Automatic Speech Recognition, Aug 2019.
- [5] Y. Hu, Evaluation of Objective Quality Measures for Speech Enhancement, Feb 2008.
- [6] N. Dimmita P. Siddaiah, Speech Recognition Using Convolutional Neural Network, Sep 2019
- [7] <https://www.kaggle.com/datasets/uwrfkagglerravdessemotional-speech-audio>
- [8] M.S. Hossain and G. Muhammad, "Emotion recognition using deep learning approach from audio-visual emotional big data," *Inf. Fusion*, vol. 49, pp. 69–78, Sep. 2019.
- [9] M. Chen, P. Zhou, and G. Fortino, "Emotion communication system," *IEEE Access*, vol. 5, pp. 326–337, 2016.
- [10] S. Lalitha, A. Madhavan, B. Bhushan, and S. Saketh, "Speech emotion recognition," in *Proc. Int. Conf. Adv. Electron. Comput. Commun. (ICAECC)*, Oct. 2014, pp. 1–4.
- [11] K. R. Scherer, "What are emotions? And how can they be measured?" *Social Sci. Inf.*, vol. 44, no. 4, pp. 695–729, 2005.
- [12] S. G. Koolagudi and K. S. Rao, "Emotion recognition from speech: A review," *Int. J. speech Technol.*, vol. 15, no. 2, pp. 99–117, 2012.
- [13] J. Schmidhuber, "Deep learning in neural networks: An overview," *Neural Netw.*, vol. 61, pp. 85–117, Jan. 2015.
- [14] S. Demircan and H. Kahramanlı, "Feature extraction from speech data for emotion recognition," *J. Adv. Comput. Netw.*, vol. 2, no. 1, pp. 28–30, 2014.



INNO SPACE
SJIF Scientific Journal Impact Factor
Impact Factor
7.521

ISSN

INTERNATIONAL
STANDARD
SERIAL
NUMBER
INDIA



INTERNATIONAL JOURNAL OF MULTIDISCIPLINARY RESEARCH IN SCIENCE, ENGINEERING AND TECHNOLOGY

| Mobile No: +91-6381907438 | Whatsapp: +91-6381907438 | ijmrset@gmail.com |

www.ijmrset.com