

e-ISSN:2582 - 7219



# INTERNATIONAL JOURNAL OF MULTIDISCIPLINARY RESEARCH IN SCIENCE, ENGINEERING AND TECHNOLOGY

Volume 4, Issue 11, November 2021



INTERNATIONAL  
STANDARD  
SERIAL  
NUMBER  
INDIA

Impact Factor: 4.988



9710 583 466



9710 583 466



ijmrset@gmail.com



www.ijmrset.com



# Design and Finite element Analysis of Rotavator Blade

CH.Siva Kumar<sup>1</sup>, U.Bhargavi<sup>2</sup>

Assistant Professor, Dept. of MECH, Brahmaiah College of Engineering, Nellore, Andhrapradesh, India<sup>1</sup>

PG Student [MD], Dept. of MECH, Brahmaiah College of Engineering, Nellore, Andhrapradesh, India<sup>2</sup>

**ABSTRACT:** The computer aided engineering analysis and design optimization of rotary tillage tool on the basis of finite element method and simulation method is done by using CAD-software for the structural analysis. In Indian farming, the preparation of seedbeds for deep tillage using additional machinery and tillage tools are increased. Rotary tiller or rotavator is one of the tilling machine most suitable for seedbed preparation. In a Rotary tillage machine, Blades are the critical parts which are engaged with soil to prepare the land and to mix the fertilizer. These blades interact with soil in a different way than normal plows which are subjected to impact that creates cyclic forces which result in fatigue failure of the blade. This actually decreases the service life of a blade. Therefore, it is necessary to design and develop a suitable blade. This paper describes the design modification and development of rotavator blade through the (CAD) interrogation method by modifying the design and also by modifying the material properties. Then better design will be compared by comparing the results.

**KEYWORDS:** rotary tillage tool, simulation, FEM, design analysis, stress, deformation, rotavator

## I.INTRODUCTION

Rotary tillage machine which is used in soil-bed preparation and weed control in arable field and

fruit gardening agriculture. It has a huge capacity for cutting, mixing to topsoil preparing the seedbed directly. And also it has more mixing capacity seven times than a plough. Its components works under miscellaneous forces because of power, vibration, pointless, impact effect of soil parts as after reaching to higher side. The design optimization and manufacturing errors can be minimized by its components design analysis and optimization. Especially blades and transmission elements have to be reliable in field the performance against to operating forces. Predicting to stress distributions is so important for the designers, manufacturers and end user. The design optimization of tillage tool is obtained by reducing its weight, cost and by improving a field performance to high weed removal efficiency .The computer aided design analysis by preparing a three dimensional solid modeling and finite elements method applications are getting so widespread in the industry. Thus due to undesired stress distributions on its components, it cannot compensate to the operating forces i.e. field environment and results in breakdown and failure due to higher stresses and deformation.The proposed work develops a computer aided experimental system for design testing and valuation of agricultural tools and equipment. The selected physical model of rotavator is measured with accurate dimensions and a solid (3-D) model is prepared in CAD-software such as ANSYS, CATIA, Pro/E, hyper mesh etc. by assembling an individual parts with detail specifications. Descriptions of FMEA Method:

### 1.1. Rotavator

Rotary tiller is a tillage machine designed for preparing land suitable for sowing seeds (without overturning of the soil), for eradicating weeds, mixing manure or fertilizer into soil, to break up and renovate pastures for crushing clods etc. It offers an advantage of rapid seedbed preparation and reduced draft compared to conventional tillage. It saved 30-35 % of time and 20-25 % in the cost of operation as compared to tillage by cultivator. It gave higher quality of work (25-30 %) than tillage by cultivator. The Rotavator is the most efficient means of transmitting engine power directly to the soil with no wheel slip and a major reduction in transmission power loss.



## 1.2 Rotavator In Agriculture

The rotavator will produce a perfect seedbed in fewer passes. It is the ideal implement for cash crop farmers who need to bury and incorporate crop residues quickly, between crops. Tillage tools direct energy into the soil to cause some desired effect such as cutting, breaking, inversion, or movement of soil. Soil is transferred from an initial condition to a different condition by this process. A rotavator is a mechanical gardening tool with power blades attached to a spinning surface to plough soil and give optimum tillage. Different rotavator are designed to suit different gardening needs.

A gardening rotavator is a compact machine which can be used on any land size but is more appropriate for gardening. Gardeners usually use a variation of this appliance as sometimes, only small flower beds or miniature vegetable patches need to be tilled. Gardening rotavator cannot really break up huge amounts of soil, but can efficiently churn up the soil and remove unnecessary weeds on the flower beds and can also ensure infusion of the fertilizer into the soil. Such a machine is usually powered by electricity, as it is not heavy-duty, making it easier to handle. In addition to this they are usually inexpensive and can be afforded by the avid gardener compared to the varieties that are run on gas or petrol. Detection is described on a 10-point scale where 10 is highest. The detect ability of failure varies from (1 = likely to be detected to 10 = very unlikely to be detected).

## II. PROBLEM IDENTIFIED

The rotavator components work under un even miscellaneous forces of cyclic loading effect of soil parts at the cutting edge. Due to the cyclic loading condition the fatigue strength and life of the blade will be affected. In order to improve the fatigue strength of the blade the design of the blade will be modified and developed.

## III. CORE CUTTER TEST

The core cutter test is basically used to find out the soil density. The soil density has to be find out for calculating the force acting on the cutting edge of the blade. The procedure for the core cutter test will be as follows. Expose approximately 300 mm square of the soil layer to be tested. Place the steel dolly on top of the cutter and hammer the latter into the soil layer until the top edge of the cutter is a few millimeters below the soil surface. Take care not to rock the core cutter. Repeat with other cores in close proximity so as to obtain sufficient replicates. Dig out the core samples, taking care not to damage them. Trim the ends of the core level with the ends of the cutter by means of a spatula and steel straight edge. Reject those that are not completely filled with soil. If the cores are satisfactory, pack them in loose soil in plastic bags or other containers. Two or three cores may be placed in one plastic bag but, in this case, wrap each core in aluminum foil. Transfer back to the laboratory in an insulated box packed with foam or vermiculite. For subsurface samples, dig a pit of the necessary size and depth, and sample as above. If desired, samples may be taken from the wall of the pit. Weight the cutter containing the wet core to the nearest gram. If the soil moves freely in the cutter, extrude the core into an aluminum tray and dry to constant weight at 105 °C. Several days may be required. Removal of the core may be assisted by partial drying as preliminary treatment, in cases where the core cannot be released from the cutter. Then the soil is dried in place for an extended period. Weigh the dry soil with the cutter and then the cutter separately. Calculate the internal volume of the core cutter, in cubic centimeters from its dimensions measured to the nearest 0.5 mm. Then the readings will be tabulated and the calculations will be carried out.

### 3.1 CALCULATIONS:

Soil requirements,

- Weight of the soil = 4.784kg
- Core cutter weight= 2.478kg

•

Core cutter requirements,

- Core diameter= 100mm
- Height of the core = 130mm
- Factor of safety =1.5



- Total Soil mass = 4.784-2.47 = 2.300kg
  - Density = mass of the soil /volume of core cutter = 2.300/0.0004183
- = 5512.789 kg/m<sup>3</sup> = 5512.789 \* 9.8\*1.5 = 81038.01 N/m<sup>3</sup>
- Load acting on the rotavator blade  
area =1319.837 N

**Table I:** Determination of Dry density of soil using Core cutter method

S.NO	DETERMINATION	1	2	3
1	Mass of core cutter and wet soil (g)	2920	3160	2910
2	Mass of core cutter (g)	970	970	970
3	Mass of wet soil (g)	1950	2190	1940
4	Volume of core (ml)	981.8	981.8	981.8
5	Bulk Density	1.99	2.23	1.98
6	Bulk unit weight	19.52	21.88	19.42
7	Mass of container +wet soil (g)	105	132	120
8	Mass of container +dry soil (g)	90	120	100
9	Mass of container (g)	20	20	20
10	Mass of dry soil (g)	1935	100	80
11	Mass of water	15	12	20
12	Water content (%)	21.4	12	25
13	Dry density	1.64	1.96	1.59
14	Dry unit weight	16.13	19.19	15.54

#### IV. METHODOLOGY AND IMPLEMENTATION

From the observation on blade failure, it is understood that all the problems are related with the material property and the design .The problem are due to

- Uneven loads
- Cyclic forces

At first the study of the blades has to carried out. After the feasibility study of blades, the test for finding the soil densities to find out the force acting on the cutting edge. Later we have to design the existing and the proposed design using the modeling software Pro-E. After the modeling process the analysis of the existing and the modified design with varying material property will be made. The materials used for the proposed model are high chromium steel, H13 steel, Die steel. The material property for these toll steels will be tabulated below.



Table II

SI No	NAME	MODULUS N/mm <sup>2</sup>	N RATIO	
1	Highcarbon steel	1.97*e <sup>5</sup>	0.29	7.48*e-9
2	Cast Iron	1.20*e <sup>5</sup>	0.28	7.28*e-9
3	Mild steel	2.10*e <sup>5</sup>	0.3	7.89*e-9

ANALYSIS OF EXISTING BLADE

Fig1: High carbon steel

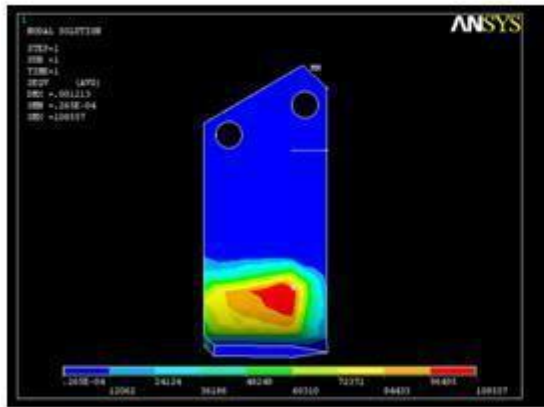

Fig 2: Mild steel

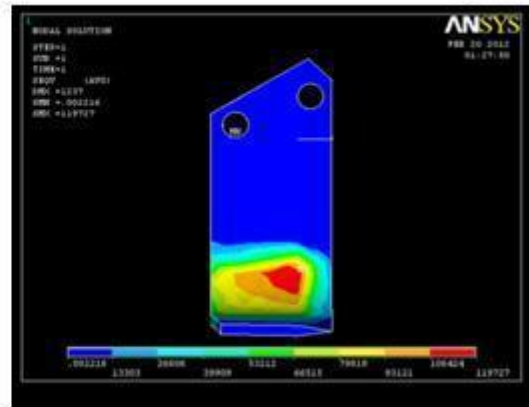

Fig 3: Cast iron

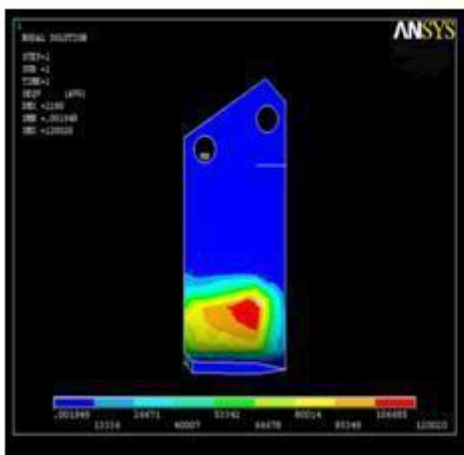

Fig 4: Modified blade design 34mm radius

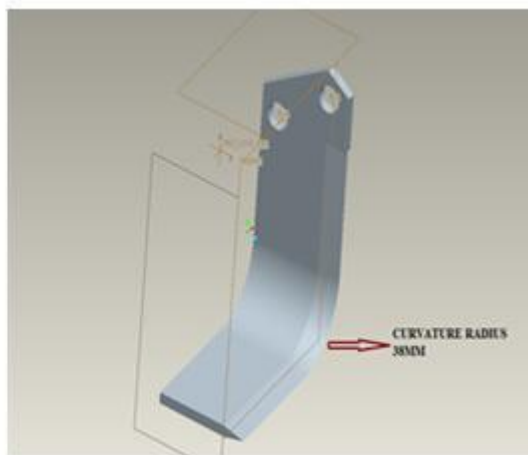
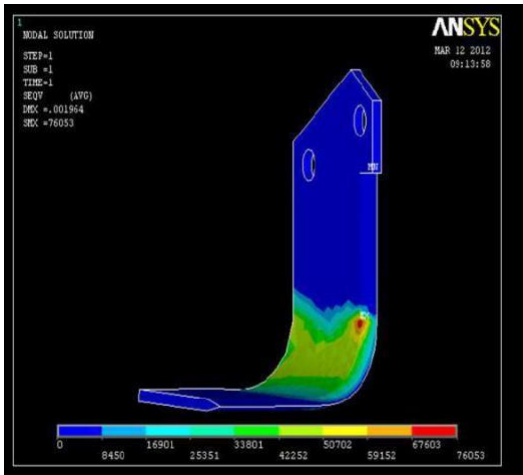
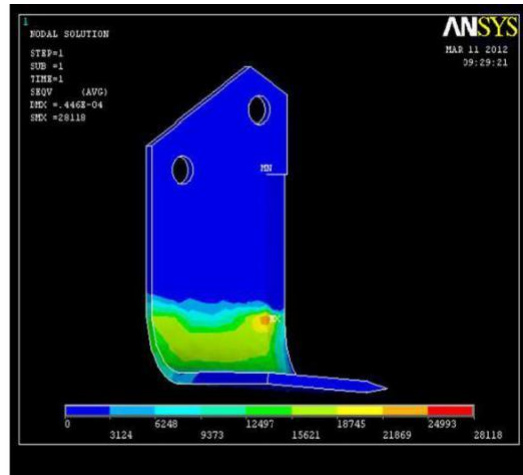



Fig 11: Die Steel



Analysis for 34mm radius Fig 12: High chromium steel



### V. RESULT AND DISCUSSION

The Finite Element Analysis was done for investigation of stresses experienced by the blade has shown in the above fig1-fig14. A comparison was made between the developed blade are made. The results showed that deformations and stresses are minimum for the developed L-type blade From the above analysis of rotavator blades, it is observed that the stress material has been reduced by applying the design change and changing the materials as

- High chromium steel (HCS),
- H13 steel,
- D3 steel.

Table IV

BLADE CURVATURE RADIUS	HIGH CHROMIUM STEEL N/mm2	H13 STEEL N/mm2	DIE STEEL N/mm2
Mm			
34	2.8118*10 <sup>4</sup>	4.9933*10 <sup>4</sup>	5.5604*10 <sup>4</sup>
36	1.19646*10 <sup>5</sup>	1.19842*10 <sup>5</sup>	1.200*10 <sup>5</sup>
38	8.8171*10 <sup>4</sup>	3.1711*10 <sup>4</sup>	7.6053*10 <sup>4</sup>

From the above table (iv), it is observed that, material selection is based on the blade radius used for plugging,

- For blade 34 mm---high chromium steel can be used.
- For blade 36mm--- high chromium steel can be used.
- For blade 38mm---H13 steel can be used.



## VI. CONCLUSION

The problems on the blade were identified and solved. The standard material used for blade is cast iron and it is producing high stress. In this project, different material compositions and dimensions are taken for analysis and the load condition is applied for existing and modified design blades. The best combination of materials and dimensions is suggested. By design change of rotavator blade we can increase the working hours of the blades and by using different materials we can increase the wear resistance of the blades.

## REFERENCES

1. Araya K, Gao R (1995). "A Non-linear three-dimensional finite element analysis of subsoiler cutting with pressurized air injection." *Journal of Agricultural Engineering Research*, 61: 115-128
2. Asabe. S, 1997. "ASAE Standards – 44th Edition (Standards Engineering Practices Data)". The Society for Engineering in Agricultural, Food, and Biological Systems, U.S.A.
3. Bernacki, H., Haman, J., Kanfojki, C.Z., 1972. "Agricultural Machines: Theory and Construction, Vol. 1."
4. The Scientific Publications Foreign Cooperative. Centre of Central Institute for Scientific Technical and Information, Warsaw, Poland, pp. 382-387
5. Boccafogli, A., Busatti, G., Gherardi, F., Malaguti, F., Paoluzzi, R., 1992. "Experimental evaluation of cutting dynamic models in soil bin facility. *J. Terramech.* 29, 95-105.
6. Gite, L.P., Bhardwaj, K.C., Bohra, C.P., 1993. "Ergonomic evaluation of wheeled type manual weeders". Paper presented during XXVIII Annual Convention of ISAE held at CIAE, Bhopal. 2-4 March 1993.



**INNO SPACE**  
SJIF Scientific Journal Impact Factor  
Impact Factor:  
5.928

**ISSN**

INTERNATIONAL  
STANDARD  
SERIAL  
NUMBER  
INDIA



# INTERNATIONAL JOURNAL OF MULTIDISCIPLINARY RESEARCH IN SCIENCE, ENGINEERING AND TECHNOLOGY



9710 583 466



9710 583 466



ijmrset@gmail.com

[www.ijmrset.com](http://www.ijmrset.com)